



注册机械画册 153 6342 6500



# 佛山市瑞普华机械设备有限公司

FOSHAN RUIPUHUA MACHINERY EQUIPMENT CO.,LTD.

地址：广东省佛山市南海区狮山镇狮山科技工业园 C 区骏业北路 9 号

Address: NO.9 Junye RD., Section C, Shishan Techoology& industrial Park, Shishan Town, Nanhai District, Foshan City, Guangdong Province, China

TEL: +86-757-81263868

FAX: +86-757-81263869

WEB: <https://www.ruipuhua.com>



手机画册



微信公众号



商城小程序



专业致力于自动理料包装解决方案  
Specialized in auto feeding and packaging solutions



CHINA·GUANGDONG  
中国·广东

佛山市瑞普华机械设备有限公司  
FOSHAN RUIPUHUA MACHINERY EQUIPMENT CO.,LTD.



# COMPANY PROFILE

## 公司简介

### 三 成立之本 ESTABLISHED

佛山市瑞普华机械设备有限公司成立于 2005 年，坐落在广东省佛山市南海经济开发区，是一家集研发设计、生产制造、安装调试与技术服务于于一体的专业化智能流水线设备生产企业，拳头产品包括食品包装机、理料线、机械手及高速口罩生产线等。公司产品主要应用于食品、医药、日用化工、五金玩具等多个行业，是桃李、盼盼、马大姐、徐福记、好丽友、金龙鱼、统一等国内外众多知名食品企业的设备供应商，产品覆盖全国 34 个省市区，远销一百多个国家，已为 4000 多家客户提供自动理料包装解决方案。

Foshan Ruipuhua Machinery Equipment Co., Ltd. was established in 2005 and is located in Nanhai Economic Development Zone, Foshan City, Guangdong Province. It is a professional intelligent assembly line equipment manufacturer integrating R&D, design, manufacturing, installation and commissioning and technical services. The leading products include food packaging machines, material sorting lines, manipulators and high-speed mask production lines. The company's products are mainly used in food, medicine, daily chemical, hardware and toys and other industries. It is an equipment supplier to many well-known food companies at home and abroad, such as Taoli, Panpan, Ma Dajie, Xu Fuji, Orion, Jin Longyu, Tongyi, etc. The products cover 34 provinces and municipalities across the country and are exported to more than 100 countries, and have provided automatic feeding and packaging solutions for more than 4,000 customers.



### 三 行业标杆 INDUSTRY BENCHMARK

公司秉承创新经营理念，专注于可持续研发能力的构建，产品和技术始终处于行业领先水平，已获取近百项国家专利，多项软件著作权。所有产品通过欧盟 CE 认证及 ISO9001 质量体系认证，行业细分市场占有率位居全国前三。近年来，先后获得“国家高新技术企业”、“全国隐形冠军”、“行业龙头企业”、“中国制造业单打冠军企业”、“国家高新区领军企业”、“佛山质量奖一线班组奖”、“瞪羚企业”等荣誉称号。2019 至 2020 年我司先后获批成立“食品理料机械标准工作组”、“食品装托机械标准工作组”及“小袋集成装袋机械标准工作组”，并担任组长单位牵头拟定行业标准。瑞普华正向着行业标准、国家标准、国际标准的制定迈进。

The company adheres to the innovative business philosophy and focuses on the construction of sustainable research and development capabilities. Its products and technologies have always been at the leading level in the industry. It has obtained nearly 100 national patents and a number of software copyrights. All products have passed the EUR CE certification and ISO9001 quality system certification, and the industry segment market share ranks among the top three in the country. In recent years, it has successively won "National High-tech Enterprise", "National Hidden Champion", "Industry Leading Enterprise", "China Manufacturing Singles Champion Enterprise", "National High-tech Zone Leading Enterprise", "Foshan Quality Award First-line Team Award", "Gazelle Enterprise" and other honorary titles. From 2019 to 2020, our company has successively been approved to establish the "Food Processing Machinery Standards Working Group", "Food Packaging Machinery Standards Working Group" and "Small Bag Integrated Bagging Machinery Standards Working Group", and served as the leader unit to lead the drafting of industry standards. Ruipuhua is moving towards the formulation of industry standards, national standards and international standards.

# 发展历程

## DEVELOPMENT HISTORY

# 携手并进 创誉辉煌

GROW TOGETHER AND BRILLIANCE TOGETHER

专注

创新

诚信

品质

服务

奋进

效率

- 2005年 瑞普华成立。  
Ruipuhua Established.
- 2008年 第一条自动理料线研发成功。  
The first automatic sorting line was successfully developed.
- 2015年 深度研发机器人应用。  
In-depth research and development of robot applications.
- 2016年 被授予“国家高新技术企业”称号。  
Was awarded the title of "National High-tech Enterprise".  
瑞普华应邀参与  
《肉松饼》行业标准的制定。  
Ruipuhua was invited to participate in the formulation of industry standards for 《Meat Muffins》.
- 2017年 瑞普华被授予“南海制造业全国隐形冠军”。  
Ruipuhua was awarded the "National Invisible Champion of Nanhai Manufacturing".  
与台湾启德强强联合。  
Started cooperation with Taiwan KEED.
- 2018年 瑞普华推出全自动二次理料包装解决方案。  
Ruipuhua launched a fully automatic secondary packing solution.

- 2018年 瑞普华接受了 CCTV 财经频道《经济半小时》栏目专访。  
Ruipuhua was interviewed by CCTV Financial Channel «Economic Half Hour».  
荣获“细分行业龙头”“单打冠军”“专精特新”“品牌企业”“科技型企业”“政府质量奖”“佛山市工程技术研究中心”等荣誉称号。  
Won the honorary titles of "Leader in the industry", "Single Champion", "Transitional Special New", "Brand Enterprise", "Technological Enterprise", "Government Quality Award", "Foshan Engineering Technology Research Center" and other honorary titles.
- 2019年 瑞普华获批组建食品理料机械标准工作组。  
Ruipuhua was approved to set up a working group for food ingredient machinery standards.  
荣获“广东省市场质量信用 A 级用户满意企业”。  
Won the "Guangdong Province Market Quality Credit A-level customer satisfaction enterprise".
- 2020年 响应政府号召，配合做好防控物资的生产供给，瑞普华发挥多年来的技术优势，整合各方资源，快速投入设计、研发和生产口罩设备。  
Responding to the government's call, and cooperating with the production and supply of prevention and control materials, Ruipuhua took advantage of its technological advantages over the years, integrated all resources, and quickly invested in the design, development and production of mask equipment.



**20<sup>+</sup>年 行业经验**  
**4000<sup>+</sup>家 客户选择我们**

**实力体现 放心之选**

# COOPERATION PARTNER

部分合作伙伴

为您提供更全面的服务体系

Provide you with a more comprehensive service system

# PRODUCT CATALOG

产品目录



## 智能包装系列 SMART PACKING SERIES

01-02  
智能包装生产线  
SMART PACKING LINE

03-04  
机械手  
THE ROBOT

## 往复式包装机系列 BOX- MOTION PACKING MACHINE SERIES

05-10  
往复式伺服包装机  
BOX-MOTION PACKING MACHINE

## 回转式包装机系列 ROTARY PACKING MACHINE SERIES

12-16  
伺服包装机  
SERVO PACKING MACHINE

17-18  
伺服无托包装机  
BISCUIT ON EDGE PACKING MACHINE

19-20  
枕式包装机  
PILLOW PACKING MACHINE



## 自动理料线系列 AUTOMATIC PACKING LINE SERIES

21-36  
全自动理料线  
AUTOMATIC PACKING LINE

37-38  
自动装托理料线  
AUTOMATIC TRAY LOADING PACKING LINE

39-40  
多通道装托理料线  
MULTI-CHANNEL TRAY LOADING PACKING LINE

41-42  
多枚装托自动理料线  
MULTI-BREAD LOADING WITH TRAY PACKING LINE

43-44  
多排多列自动理料线  
HAMBURGER PACKING LINE

## 组合式包装理料系列 COMBINED PACKING LINE SERIES

45-46  
组合式包装理料线  
COMBINED PACKING LINE

## 自动套袋包装机系列 AUTOMATIC BAG PACKING MACHINE SERIES

47-48  
自动套袋包装机  
AUTOMATIC BAGGING AND PACKING MACHINE

49-50  
自动理料系统功能配置  
FUNCTION DEVICES

## SMART PACKING LINE

### 智能包装生产线

开箱机  
carton erecting machine

封箱机  
carton sealing machine

装箱机  
carton packing machine

产品排列机  
product sorting machine

自动包装机  
packing machine

自动理料线  
auto feeding line

滚筒输送线  
roller conveyor

### 性能特点 PERFORMANCE CHARACTERISTICS

此自动包装系统包括一拖四的自动理料线、四台包装机、两台产品排列机、一台自动开箱机、两台自动装箱机、一台自动封箱机和滚筒输送线。

The auto packing system includes 4 auto feeding lines, 4 packing machines, 2 product sorting machines, 1 auto carton erecting machine, 2 auto carton packing machines, 1 auto carton sealing machine and the roller conveyor.





质量保障  
QUALITY ASSURANCE



精准操作  
PRECISE OPERATION



智能控制  
INTELLIGENT CONTROL



### 性能特点 PERFORMANCE CHARACTERISTICS

机械手具有定位精度高、稳定可靠、速度快等特点，其出众的机器人控制系统、智能视觉软件以及步进式传送带同步集成控制，可根据客户不同的需求提供解决方案。

控制系统简化了机器人的操作方式，使得机器人的控制过程更加简单，为用户和集成商提供极大的便利。同时，可以根据实际的生产调节自动进行路径优化以减少节拍时间，极大提升机器人的工作效率。

1. 定位精准：配备视觉定位及传送带跟踪管理系统，可对产品的形状、姿态进行识别并准确定位、抓取，且重复定位精度达  $\pm 0.1\text{mm}$ 。
2. 稳定可靠：采用强大的运控技术，使机器人在高速运动时，动作更平滑，运动更平稳。
3. 外观精致：坚持打造艺术品的产品设计理念，无论是从选材还是到工艺，都经过了严苛的把关。

The robot has the advantages of high precision, stable and reliable, fast its superior robot control system, intelligent visual software and a step type conveyor belt synchronous integrated control can provide solutions according to the different needs of customers. The control system simplifies the operation of the robot, the robot control process is more concise and comprehensive, providing great convenience for users and integrators. At the same time, this control system can automatically optimize the path according to the actual change of production to reduce the takt time, greatly enhance the working efficiency of the robot.

1. Positioning precision: equipped with visual positioning and conveyor belt tracking management system, can accurate positioning, grab the products according to the shape and status, and repeated positioning accuracy of 0.1mm.
2. Stable and reliable: by using the strong motion control technology, the robot move more smoothly and stably at high speed.
3. Exquisite appearance: insist on creating the art of product design concept, whether from the material or to the process, have passed the stringent checks.

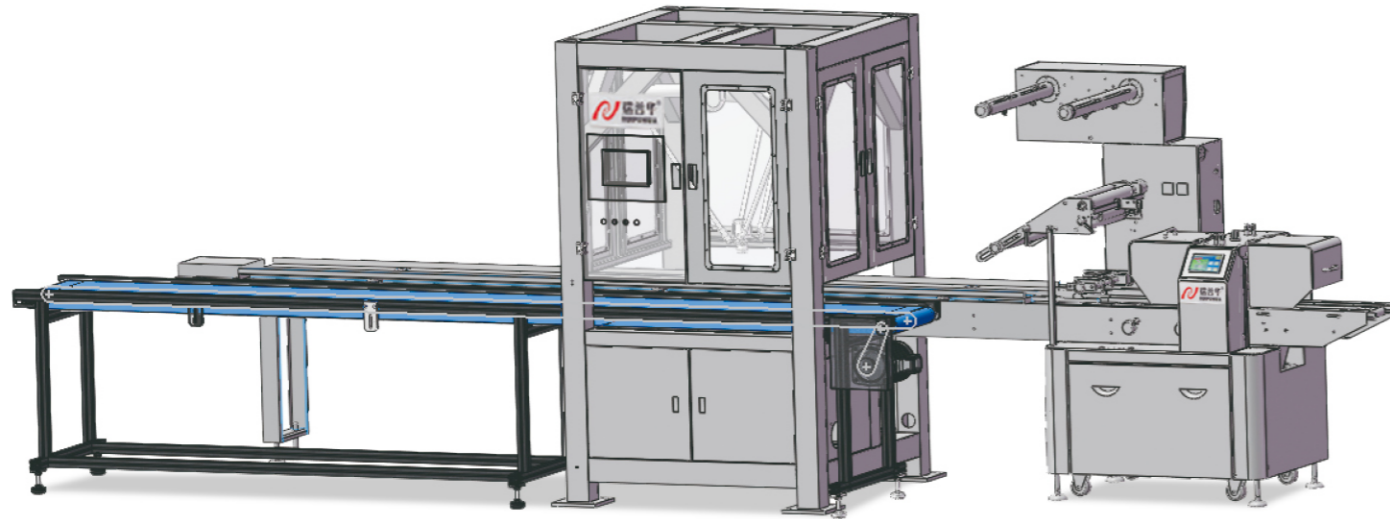

### 适用范围 APPLICATION SCOPE

机械手主要填补自动理料系统现有功能的空白，广泛应用于多个产品的装盒、二次包装（装箱），以及异形产品的整理等。

The robot mainly to fill the blank of the auto feeding system. It is widely used in multiple products loading in the tray, secondary packing (carton loading), and special-shaped products sorting.

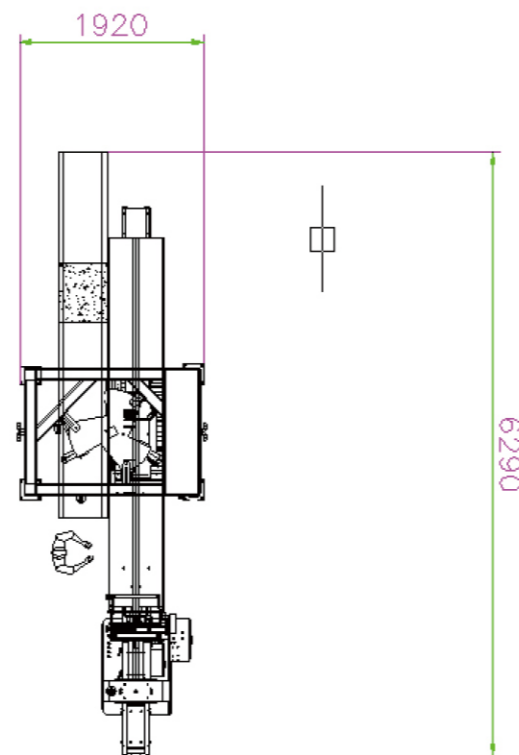

### 技术参数 TECHNICAL PARAMETER

|                                      |  |
|--------------------------------------|--|
| 负载能力 Load Capacity                   | 3kg  |
| 运动空间 Move Space                      | 直径 1130mm, 高 425mm<br>Diameter: 1130mm, Height: 425mm  |
| 轴数 Number of axes                    | 3or4   |
| 速度 Speed                             | 节拍 0.32s (3 轴, 0.1Kg 载荷) Time 0.32e (3 axes, 0.1Kg load)<br>节拍 0.35s (4 轴, 0.1Kg 载荷) Time 0.35s (4 axes, 0.1Kg load) |
| 安装方式 Installation method             | 倒置式 Inverted   |
| 重复定位精度 Repeated positioning accuracy | $\pm 0.1\text{mm}$ (When the belt speed 200mm/s)   |
| 电源电压 Supply voltage                  | 直流: 24V, 6A DC: 24V, 6A<br>交流: 单相 200-240V 10A<br>AC: single phase 200-240V 10A                                      |
| 功耗 Power                             | 2.5kW ( 载荷 1Kg 时 ) 2.5kW (Load 1Kg)  |
| 主体重量 Body weight                     | 55Kg   |



## BOX-MOTION PACKING MACHINE SERIES

### 往复式伺服包装机 RD-BM-408S



### 适用范围 APPLICATION SCOPE

适用于月饼、蛋糕、面包、饼干或者冷冻产品等。

Buns, breads, cakes, biscuit, frozen foods and trays or boxes.



### 性能和结构 FUNCTION & STRUCTURE

1. 采用往复式横封刀座设计，外观美观，密封性能好。
2. 悬臂框架式设计机身，坚固耐用耐用。
3. 输送机采用全皮带式设计，简单保养，操作更简易。
4. 全不锈钢 304 机身，符合食品级要求。
5. 全罩式安全护盖，配备安全保护开关（警示停机），避免操作意外的发生。
6. 机身紧凑，长度不超过 2 米，节省空间。
7. 伺服电机驱动，电脑控制。
8. 机械部件少，易维护，噪音少。

- 1.Box-motion End-seal: Very good-looking and well-sealed packages.
- 2.Strong machine body: Cantilever machine frame + integrated electrical cabinet.
- 3.Belt feeding design: Easily operation and daily cleaning.
- 4.Sanitary standard: SUS304 machine housing to meet highly regulated food grade standard.
- 5.Full-cover safety cover, equipped with a safety switch (alarm stop), to avoid the occurrence of accidents.
- 6.Compact and small: No more than 2-meter long.
- 7.Smart & high tech: Servo motor driven and computer controlled.
- 8.Easy maintenance: Less mechanical parts and lower operating noises.



质量保障  
QUALITY ASSURANCE



精准操作  
PRECISE OPERATION



智能控制  
INTELLIGENT CONTROL

### 产品优势 PRODUCT ADVANTAGES

1. 人机界面：7.2 寸彩色触摸屏，操作简易。
2. 记忆菜单：可记忆储存 100 组包装产品设定，切换产品快速不浪费时间。
3. 皮带输送：使用简单，且可快速拆装，方便清洁保养。
4. 快拆设计：专利快拆皮带设计，无需使用工具，徒手可直接拆换。
5. 无料待机：自动侦测模式下，无料自动待机，无空包产生，不浪费包材。
6. 往复式刀座设计：切刀不易损耗，且无需调整。
7. 误切防护设计：避免误切造成产品损坏浪费。

- 1.HMI Touch screen: 7.2 inch color touch panel, easier for user to operate the machine.
- 2.100 Recipes: Able to save up-to 100 product recipes for any complicated production.
- 3.Belt feeding: Easily for the user to do manual product loading and belt cleaning.
- 4.Smart belt design: patent fast dismantle belt design, easily removable belt without any help of tools.
- 5.No product no pack function: With this function, no empty bag and no waste will be produced.
- 6.Box-motion design: Blade is not easy to wear out, and no need to adjust.
- 7.MIS. Function (Misplaced Item Skip): Efficiently to reduce waste and avoid incorrect cutting.

### 技术参数 TECHNICAL PARAMETER

|                         |   |
|-------------------------|---|
| 型号 Model                | RD-BM-408S  |
| 包装速度 Packing speed      | 35-80bags/min 不同的产品和包装膜特性会影响速度<br>Different product and films may affect the speed                          |
| 制袋尺寸 Bag former         | L:100-400mm,W:50-140mm,H:5-70mm   |
| 包装膜宽 Film width         | 100-400mm   |
| 包装材料 Packing material   | KNY+PE/KNY+CPP/OPP+CPP / PET+CPP / PET+ VMCPP   |
| 外形尺寸 Machine size       | 皮带输送设计 (Belt design) : (L)2020 x (W)990 x (H)1400mm<br>推料块输送设计 (Belt design) : (L)2260 x (W)990 x (H)1400mm |
| 总功率 Total power         | 3.5kW   |
| 电源设备 Power & connection | 电压 (Voltage):220V, 单相 (Single phase):50/60HZ, 气压 (Air pressure):0.6MPA                                      |
| 整机重量 Weight             | 700kg   |

# BOX-MOTION PACKING MACHINE

## 往复式伺服包装机 RD-BM-508S/708S



质量保障  
QUALITY ASSURANCE



精准操作  
PRECISE OPERATION



智能控制  
INTELLIGENT CONTROL



### 产品优势 PRODUCT ADVANTAGES

1. 多样包装：适用多样性包装，一套设备可胜任尺寸大小不同产品的包装。
2. 快拆设计：专利快拆皮带设计，无需使用工具，徒手可直接拆换。
3. 人机界面：10.4 寸触控面板，操作容易。
4. 记忆菜单：可记忆储存 100 组包装产品设定，切换产品快速不浪费时间。
5. 误切防护：防止误切发生，避免误切时造成的产品浪费。
6. 无料待机：自动侦测模式下，无料自动待机，无空包产生，不浪费包材。
7. 故障排除：自动故障排除，减少时间消耗。

1. Diversified packaging: suitable for diverse packaging, a set of equipment can be capable of packaging products of different sizes.
2. Quick release design: Patented quick release belt design, no need to use tools, can be directly disassembled and replaced with bare hands.
3. Man-machine interface: 10.4 inch touch panel, easy to operate.
4. Memory menu: 100 sets of packaging product settings can be stored in memory, switching products quickly without wasting time.
5. Miscutting protection: Miscutting occurs when placed to avoid product waste caused by miscutting.
6. No material standby: In automatic detection mode, there is no material standby automatically, no empty bag is generated, and no packaging material is wasted.
7. Troubleshooting: automatic troubleshooting, reducing time consumption.



### 性能和结构 FUNCTION & STRUCTURE

1. 采用往复式横封刀座设计。
2. 悬臂框架式设计机身，坚固耐久耐用。
3. 输送机采用全皮带式设计，简单保养，操作更简易。
4. 不锈钢机身，符合食品级要求。
5. 全罩式安全护盖，配备安全保护开关（警示停机），避免操作意外的发生。
6. 提供正反向机，客户可依照需求选择。

- 1.Box-motion End-seal design: Featuring easy maintenance and hermetic sealing.
- 2.Heavy duty design: Cantilever build / Heavy steel mainframe and SUS304 made housing, with integrated electrical cabinet, perfect for multi-shift operation.
- 3.Belt feeding design: Easier for users to manually load products, easily removable belt without any help of tools, ideal for everyday cleaning.
- 4.Sanitary standard: SUS304 machine housing designed to meet highly regulated food grade standard.
- 5.Safety guard design: Fully safety-guarded to protect operators from accidental jamming or cutting.
6. Forward and reverse machine design: Customers can choose according to their demand.



### 适用范围 APPLICATION SCOPE

适用于烘焙类面包蛋糕、速冻包子馒头、带托盒水饺、熟食袋、汉堡等。针对较高的产品更有优势。

Suitable for baking bread cakes, quick-frozen steamed buns, dumplings with trays, cooked food bags, burgers, etc. It is more advantageous for higher products.



### 技术参数 TECHNICAL PARAMETER

| 型号 Model                | RD-BM-508S   | RD-BM-708S                               |
|-------------------------|--|--|
| 包装速度 Packing speed      | 35-120bags/min   | 30-60bags/min                            |
|                         | 不同的产品和包装膜特性会影响速度 Different product and films may affect the speed      |  |
| 制袋尺寸 Bag former         | L: 100-500mm, W: 50-200mm<br>H: 5-100mm                                | L: 180-500mm, W: 50-300mm,<br>H: 5-120mm |
| 包装膜宽 Film width         | Max:500mm  | Max:670mm                                |
| 包装材料 Packing material   | KNY+PE/KNY+CPP/OPP+CPP / PET+CPP / PET+ VMCPP                          |  |
| 外形尺寸 Machine size       | (L)4000mmX(W)1139mmX(H)1680mm  | (L)4300mmX(W)1250mmX(H)1700mm            |
| 总功率 Total power         | 3.5KW  |  |
| 电源设备 Power & connection | 电压 (Voltage):220V, 单相 (Single phase):50/60HZ, 气压 (Air pressure):0.6MPA |  |
| 整机重量 Weight             | About1400kg  |  |

# BOX-MOTION PACKING MACHINE (DOWN FILM)

▲ 往复式伺服包装机（下走膜） RD-BMD-508S/708S



质量保障  
QUALITY ASSURANCE



精准操作  
PRECISE OPERATION



智能控制  
INTELLIGENT CONTROL



## 适用范围 APPLICATION SCOPE

适用于饼干、威化饼、面包、蛋糕、方便面等规则产品的二次包装。  
It is suitable for the secondary packing of biscuits, waffles, bread, cakes, instants noodles and other regular products.



## 产品优势 PRODUCT ADVANTAGES

1. 减少机械零件，降低噪音，维修容易。
2. 悬臂框架式设计机身，坚固耐久耐用。
3. 输送机配备宽度调整手轮，调整方便快速。
4. 提供 SUS304 防锈防水版本，符合高等食品级要求。
5. 全罩式安全护盖，配备有安全保护开关（警示停机），避免操作意外的发生。
6. 实现您全自动化包装线的理想，提供自动整列、自动送料、产品集合等专业规划设计服务。
7. 配备自动接纸装置，减少换膜浪费时间，提升产能效益。

1. Reduce mechanical parts, reduce noise, and easy maintenance.
2. Cantilever frame design body, strong and durable.
3. The conveyor is equipped with a width adjustment handwheel, which is convenient and quick to adjust.
4. Provide SUS304 anti-rust and waterproof version, which meets high food grade requirements.
5. Full cover type safety cover, equipped with safety protection switch (warning shutdown), to avoid accidental operation.
6. Realize your ideal of a fully automated packaging line, and provide professional planning and design services such as automatic alignment, automatic feeding, and product accumulation.
7. Equipped with automatic paper splicing device to reduce wasted time for film changing and improve productivity.

## 技术参数 TECHNICAL PARAMETER

| 型号 Model                | RD-BMD-508S  | RD-BMD-708S                             |
|-------------------------|--|---|
| 包装速度 Packing speed      | 30-60bags/min 不同的产品和包装膜特性会影响速度<br>Different product and films may affect the speed |   |
| 制袋尺寸 Bag former         | L: 100-500mm, W: 50-200mm,<br>H: 5-100mm   | L: 180-500mm,W: 50-300mm,<br>H: 5-120mm |
| 包装膜宽 Film width         | Max:500mm  | Max:670mm                               |
| 包装材料 Packing material   | KNY+PE/KNY+CPP/OPP+CPP / PET+CPP / PET+ VMCPP                                      |   |
| 外形尺寸 Machine size       | (L)6000mmX(W)1300mmX(H)1900mm  |   |
| 总功率 Total power         | 3.5kW  |   |
| 电源设备 Power & connection | 电压 (Voltage):220V, 单相 (Single phase):50/60Hz, 气压 (Air pressure):0.6MPA             |   |
| 整机重量 Weight             | 1500kg   |   |

\*备注：以上规格仅供参考，实际依据客户需求设计。  
The above specifications are for reference only and are designed according to the actual needs of customers.

03

## ROTARY PACKING MACHINE SERIES

### ▲ 回转式包装机系列

## SERVO PACKING MACHINE

### ▲ 伺服包装机 ZP-500SG



### 性能 and 结构 FUNCTION & STRUCTION

1. 具有菜单储存记忆功能，控制器能够保存多组参数配置，更换产品或包装膜时在触摸屏上调出配方即可使用。
2. 行业领先的电子凸轮算法，袋长范围 60mm- 无限长，袋长即设即切，一步到位，省时省膜。
3. 先进电子防切料，电子防空包算法。空料膜停止，节省包材。
4. 横封、纵封、送料均采用独立伺服电机控制，机械结构简洁，运行平稳，噪声小。

1. With menu storage memory function, can use the memory formula from the touch screen according to different products or packaging film.
2. With the industry leading electronic cam algorithm, bag length range from 60 mm to infinite, The bag actual length takes effect immediately after setting, save time and packaging film.
3. Advanced algorithm for preventing cutting products and empty bag. Packaging film stops feeding when no product, save materials.
4. The horizontal sealer, vertical sealer and products feeding are controlled by independent servo motor. Mechanical structure is simple, operation is stable and small noise.

### 技术参数 TECHNICAL PARAMETER

|                       |   |
|-----------------------|---|
| 型号 Model              | ZP-500SG                                  |
| 包装速度 Packing speed    | 35-300 bags/min                           |
| 制袋尺寸 Bag former       | (L)60- 无限长 Infinite,(W)30-150mm,(H)5-50mm |
| 包装膜宽 Film width       | 65-400mm                                  |
| 包装材料 Packing material | OPP/CPP,PT/PE,KOP/CPP,ALU-FOIL            |
| 外形尺寸 Machine size     | (L)4000 X (W)960 X (H)1600mm              |
| 加热功率 Heating power    | 3.8kW                                     |
| 电机功率 Motor Power      | 2.5kW                                     |
| 总功率 Total power       | 6.3kW                                     |
| 整机重量 Weight           | 550kg                                     |

\*注：更换刀封中心距可变化制袋高度尺寸。  
\*Note: Changing the center distance of the knife seal can change the height of the bag.

# SERVO PACKING MACHINE

▲ 伺服包装机 ZP-480SG



## 技术参数 TECHNICAL PARAMETER

|                       |   |
|-----------------------|---|
| 型号 Model              | ZP-480SG                                    |
| 包装速度 Packing speed    | 35-100 bags/min                             |
| 制袋尺寸 Bag size         | (L)120mm- 无限长 Infinite(W)50-160mm(H)30-80mm |
| 包装膜宽 Film width       | 65-450mm                                    |
| 包装材料 Packing material | OPP/CPP、PT/PE、KOP/CPP、ALU-FOIL              |
| 外形尺寸 Dimension        | (L)4000mmX(W)960mmX(H)1600mm                |
| 加热功率 Heat power       | 2.4kW                                       |
| 电机功率 Motor power      | 2.5kW                                       |
| 总功率 Total power       | 4.9kW                                       |
| 机器重量 Overall weight   | 550kg                                       |

## 适用范围 APPLICATION SCOPE

适用于面包、蛋糕、月饼、纸巾等各类固态规则或带托盒物品的包装。

Suitable for packing various solid regular objects, such as bread, cake, moon cake, tissue or under with tray/box.



# SERVO DOWN FILM PACKING MACHINE

▲ 伺服下走膜包装机 ZP-3000S

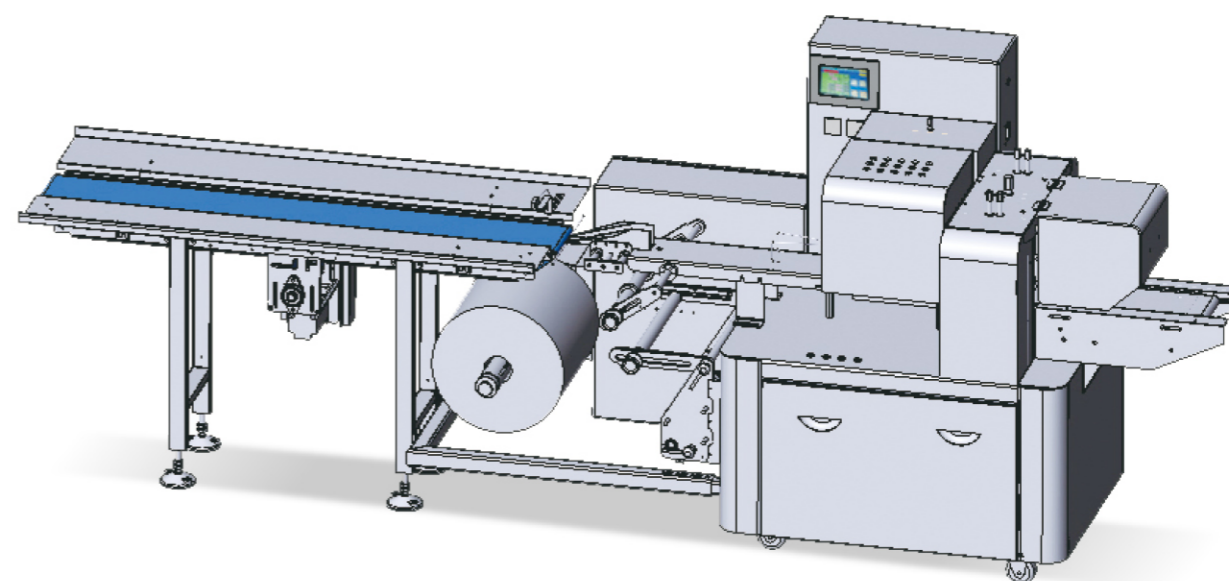

## 适用范围 APPLICATION SCOPE

适用于蒸蛋糕、蜜饯果脯、湿纸巾、五金零件、药品、酒店一次性用品及蔬果类等具有粘性、柔软状、长条状等不规则物品的包装。

It is suitable for the packing of sticky, soft, long strips and other irregular items such as steamed cakes, candied fruits, wet paper towels, hardware parts, medicines, hotel disposable products, and vegetables and fruits.

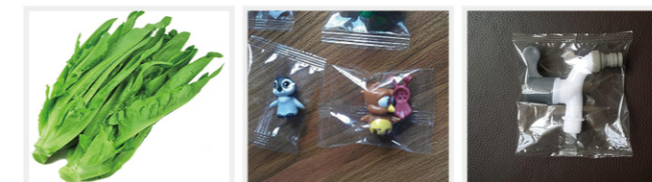

## 技术参数 TECHNICAL PARAMETER

|                       |   |
|-----------------------|---|
| 型号 Model              | ZP-3000S<br>(皮带式 Belt type/ 链条式 Chain type)     |
| 包装速度 Packing speed    | 35-150bags/min<br>10-60bags/min (Free length)   |
| 制袋尺寸 Bag size         | (L)90mm- 无限长 Infinite,<br>(W)30-140mm,(H)5-50mm |
| 包装膜宽 Film width       | 65-400mm  |
| 包装材料 Packing material | OPP/CPP,PT/PE,KOP/CPP,ALU-FOIL                  |
| 外形尺寸 Dimension        | (L)4000mmX(W)960mmX(H)1400mm                    |
| 加热功率 Heat power       | 3.8kW   |
| 电机功率 Motor power      | 2.5kW   |
| 总功率 Total power       | 6.3kW   |
| 机器重量 Overall weight   | 630kg   |

# SERVO PACKING MACHINE

## 伺服包装机 ZP-530S



质量保障  
QUALITY ASSURANCE



精准操作  
PRECISE OPERATION



智能控制  
INTELLIGENT CONTROL

## 产品优势 PRODUCT ADVANTAGES

1. 具有菜单储存记忆功能，控制器能够保存多组参数配置，更换产品或包装膜时在触摸屏上调出配方即可使用。
2. 行业领先的电子凸轮算法，袋长范围 60mm--- 无限长，袋长即设即切，一步到位，省时省膜。
3. 先进电子防切料，电子防空包算法。空料膜停止，节省包材。
4. 横封、纵封、送料均采用独立伺服电机控制，机械结构简洁，运行平稳，噪声小。
5. 配线时自动跟踪进料速度，包装机自动加减速度。高速度，高精度，双刀速度可达 300 包 / 分钟。
6. 人机界面，参数设定方便快捷，色标自动跟踪，自动修正裁切长度。数字化输入封切位置，使封切位置更加精确。
7. 故障自动诊断，故障显示一目了然。
8. 自动对中双托纸、自动接膜、出料毛刷、知名品牌伺服电机 / PLC / 触摸屏此为单机标配。
9. 防切料、防空包、充气、喷酒精、提升面板、打码机、中封毛刷、不锈钢为单机选配。
10. 标配横封刀轴中心距为 132，可改为刀距 105 或 90，根据产品实际外形尺寸，当产品偏小，要求的包装速度较高时（比如 300 包 / 分以上），可选用刀距 105 或 90。

1. With menu storage memory function, can use the memory formula from the touch screen according to different products or packaging film.
2. With the industry leading electronic cam algorithm, bag length range from 60 mm to infinite, The bag actual length takes effect immediately after setting, save time and packaging film.
3. Advanced algorithm for preventing cutting products and empty bag. Packaging film stops feeding when no product, save materials.
4. The horizontal sealer, vertical sealer and products feeding are controlled by independent servo motor. Mechanical structure is simple, operation is stable and small noise.
5. The packing machine can track the feeding speed automatically when connected with line. High precision, high speed up to 300 packs/ per minute with double blades.
6. Human-machine interface, parameter setting is easy and convenient, color mark can automatically track and correct cutting length. Digital input of cutting position makes the sealing and cutting more accurate.
7. Self failures diagnosis, clear failure display.
8. Automatic alignment of single paper, well-known brand servo motor / PLC / touch screen. above these are machine standard.
9. Double film support rollers, automatic film connection, inflatable, alcohol spray, lifting panel, date printer, vertical seal / output brush, fully stainless steel frame. preventing cutting products & empty bag, Above these are machine optional device.
10. The center distance of the standard horizontal seal knife shaft is 132, which can be changed to 105 or 90 when the product is small and the required packing speed is high (such as 300 packets / min or above).

## 技术参数 TECHNICAL PARAMETER

|                       |   |
|-----------------------|---|
| 型号 Model              | ZP-530S                                       |
| 包装速度 Packing speed    | 35-300 bags/min                               |
| 制袋尺寸 Bag former       | (L)60mm- 无限长 Infinite, (W)30-150mm, (H)5-50mm |
| 包装膜宽 Film width       | 65-400mm                                      |
| 包装材料 Packing material | OPP/CPP, PT/PE, KOP/CPP, ALU-FOIL             |
| 外形尺寸 Machine size     | (L)4000mm X (W)900mm X (H)1600mm              |
| 加热功率 Heating power    | 3.8kW   |
| 电机功率 Motor Power      | 2.5kW   |
| 总功率 Total power       | 6.3kW   |
| 整机重量 Weight           | 630kg   |

\*注：更换刀封中心距可变化制袋高度尺寸。  
\*Note: The height of bag making can be changed by changing the center distance of the knife seal.

## 适用范围 APPLICATION SCOPE

适用于蛋糕、面包、月饼、饼干、日用化工、五金零件等有规则物品的包装。

Suitable for packing various solid regular objects, such as cake, bread, biscuit, daily items, hardware parts and so on



# BISCUIT ON EDGE PACKING MACHINE

## 伺服无托包装机 ZP-500W



质量保障  
QUALITY ASSURANCE



精准操作  
PRECISE OPERATION



智能控制  
INTELLIGENT CONTROL

## 产品优势 PRODUCT ADVANTAGES

1. 具有菜单储存记忆功能，控制器能够保存多组参数配置，更换产品或包装膜时在触摸屏上调出配方即可使用。
2. 行业领先的电子凸轮算法，袋长即设即切，一步到位，省时省膜。
3. 先进电子防切料，电子防空包算法。空料膜停止，节省包材。
4. 横封、纵封、送料均采用独立伺服电机控制，机械结构简洁，运行平稳，噪声小。
5. 配线时自动跟踪进料速度，包装机自动加减速。高速度，高精度，双刀速度可达 120 包 / 分钟。
6. 人机界面，参数设定方便快捷，色标自动跟踪，自动修正裁切长度。数字化输入封切位置，使封切位置更加精确。
7. 故障自动诊断，故障显示一目了然。
8. 单托纸、知名品牌伺服电机 / PLC / 触摸屏此为单机标配。
9. 双托纸、自动接膜、打码机、防空包、防切料、提升面板、充气、出料毛刷、不锈钢为单机选配。
10. 标配横封刀轴中心距为 132，根据产品实际外形尺寸，可更换横封中心距。

1. With menu storage and memory function, the controller can save multiple sets of parameter configurations, and when the product or packaging film is changed, the recipe can be used by calling out on the touch screen.
2. The industry-leading electronic cam algorithm, the bag length is set and cut, one step is in place, saving time and film.
3. Advanced electronic anti-cutting, electronic anti-aircraft bag algorithm. The empty material film stops, saving packaging materials.
4. Horizontal sealing, vertical sealing, feeding and discharging are all controlled by independent servo motors, with simple mechanical structure, stable operation and low noise.
5. Automatically track the production feeding speed, and the packaging machine automatically accelerates and decelerates. High speed, high precision, speed up to 120 packs/min.
6. Man-machine interface, convenient and quick parameter setting, automatic tracking of color code, automatic correction of cutting length. Digitally input the sealing and cutting position to make the sealing and cutting position more accurate.
7. The fault is automatically diagnosed, and the fault display is clear at a glance.
8. Single support paper, well-known brand servo motor/PLC/touch screen This is the standard configuration of a single machine.
9. Double support paper, automatic film splicing, anti-cutting material, anti-aircraft bag, inflating, alcohol spraying, lifting panel, coding machine, discharging brush, stainless steel are optional for single machine.
10. The standard horizontal sealing cutter shaft center distance is 132, and the horizontal sealing center distance can be changed according to the actual size of the product.

## 技术参数 TECHNICAL PARAMETER

|                       |  |
|-----------------------|--|
| 型号 Model              | ZP-500W                                      |
| 包装速度 Packing speed    | 30-120 bags/min                              |
| 制袋尺寸 Bag former       | (L)60mm- 无限长 Infinite,(W)30-150mm,(H)30-75mm |
| 包装膜宽 Film width       | 65-400mm                                     |
| 包装材料 Packing material | OPP/ CPP,PT/PE,KOP/ CPP,ALU-FOIL             |
| 外形尺寸 Machine size     | (L)4600mmX(W)960mmX(H)1600mm                 |
| 加热功率 Heating power    | 3.8kW  |
| 电机功率 Motor Power      | 2.5kW  |
| 总功率 Total power       | 6.3kW  |
| 整机重量 Weight           | 820kg  |

## 适用范围 APPLICATION SCOPE

针对饼干类多片排列包装的产品，可人工放料，也可前端对接饼干计数理料机，进行输送包装。

For biscuit products with multi-piece packaging, it can be manually feeding product, or automatically connect to the production line, equipped with biscuit counting and sorting conveying and packaging machine.



# PILLOW PACKING MACHINE

## 枕式包装机 ZP-100



### 技术参数 TECHNICAL PARAMETER

|                       |                                |
|-----------------------|--------------------------------|
| 型号 Model              | ZP-100                         |
| 包装速度 Packing speed    | 35-220 bags/min                |
| 制袋尺寸 Bag size         | (L)65-200mm(W)30-90mm(H)5-30mm |
| 包装膜宽 Film width       | 65-220mm                       |
| 包装材料 Packing material | OPP/CPP PT/PE KOP/CPP ALU-FOIL |
| 外形尺寸 Dimension        | (L)4000mmX(W)850mmX(H)1600mm   |
| 加热功率 Heat power       | 2.4kW                          |
| 电机功率 Motor power      | 0.6kW                          |
| 总功率 Total power       | 3kW                            |
| 机器重量 Overall weight   | 550kg                          |

### 适用范围 APPLICATION SCOPE

适用于饼干、曲奇、棒棒冰、雪饼、巧克力、糖果、小月饼、绿豆饼、药品、日常用品、五金零件等各类固态规则物品的包装。

Applicable for packing various solid regular objects, such as biscuits, cookies, ice pops, snow cake, chocolate, candy, medicine, daily items, hardware parts and so on.



# PILLOW PACKING MACHINE

## 枕式包装机 ZP-500



### 技术参数 TECHNICAL PARAMETER

|                       |                                |
|-----------------------|--------------------------------|
| 型号 Model              | ZP-500                         |
| 包装速度 Packing speed    | 35-350bags/min                 |
| 制袋尺寸 Bag size         | (L)85-230mm(W)20-90mm(H)5-50mm |
| 包装膜宽 Film width       | 65-280mm                       |
| 包装材料 Packing material | OPP/CPP、PT/PE、KOP/CPP、ALU-FOIL |
| 外形尺寸 Dimension        | (L)4000mmX(W)770mmX(H)1600mm   |
| 加热功率 Heat power       | 3.1kW                          |
| 电机功率 Motor power      | 1.3kW                          |
| 总功率 Total power       | 4.4kW                          |
| 机器重量 Overall weight   | 750kg                          |

### 适用范围 APPLICATION SCOPE

适用于米果、棉花糖、手指面包、燕麦巧克力、酥糖、松塔、果仁酥等有规则物体的包装。

Applicable for rice bar, marshmallow, chocolate, candy, pie. Any kind of products and so on.





# AUTOMATIC PACKING LINE SERIES

## 全自动理料线

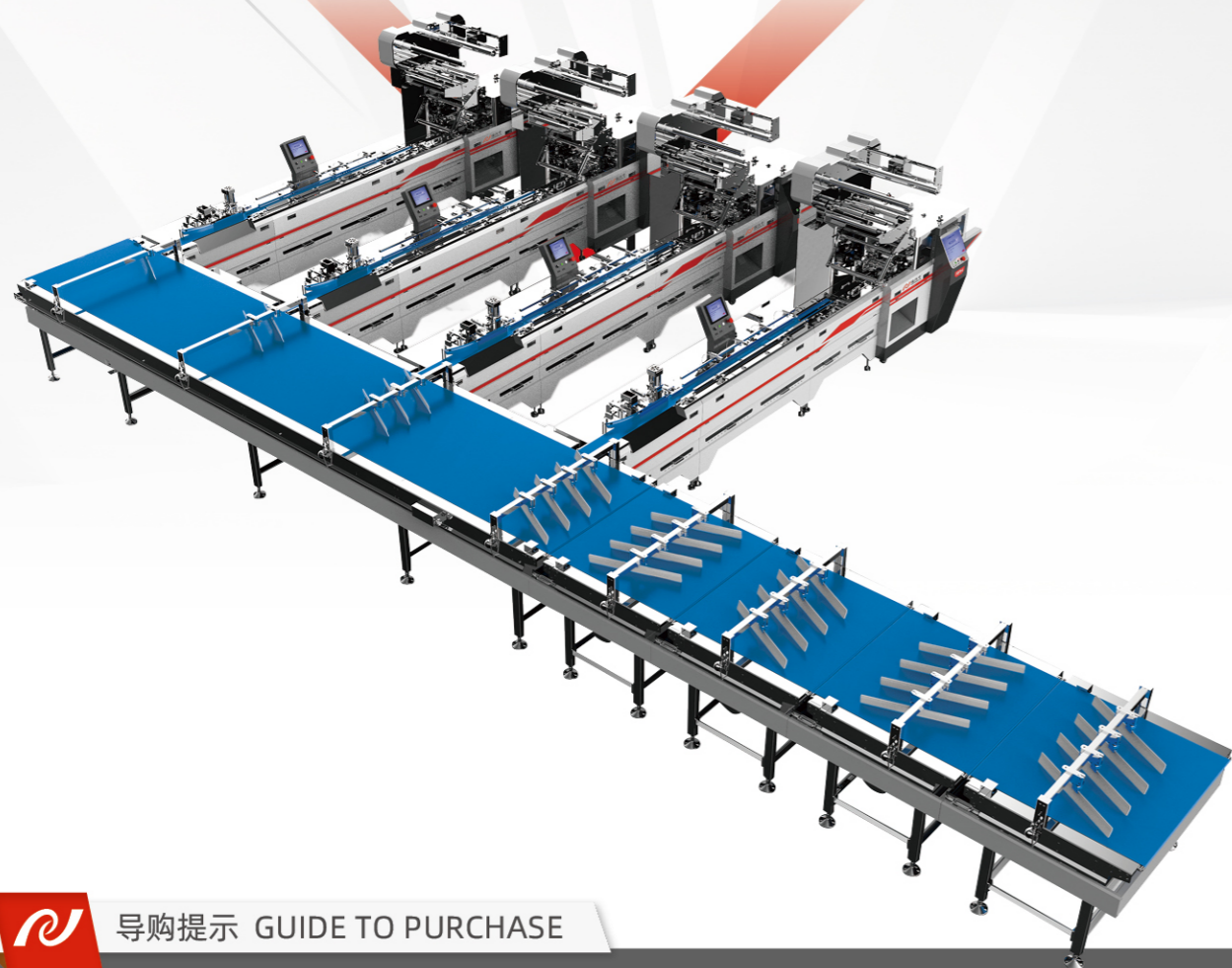

质量保障  
QUALITY ASSURANCE



精准操作  
PRECISE OPERATION



智能控制  
INTELLIGENT CONTROL



## 性能特点 PERFORMANCE CHARACTERISTICS

1. 自动理料系统经专业的工业外观设计师设计，遵循美学观点和原理，进一步优化传动和功能性结构，充分考虑美观度和可操作性，塑造高端品牌形象。
2. 整列（排）输送机可实现物料排列整齐、高速稳定、操作简易。
3. 自动理料机组输送带可实现无工具快速拆装，输送带下方及接口处配备接渣槽，方便设备维护清洁，省时省力。
4. 整线选用优质食品等级输送带。
5. 控制系统采用高品质电器元件，配备伺服电机，PLC 控制，触摸屏操控显示，良好的人机界面，操作简单、直观、方便。

- 1.The automatic feeding system is designed by professional industrial appearance designers. According to the aesthetic viewpoint and principle, the transmission and functional structure are further optimized, the aesthetic degree and operability are fully considered, and the high-end brand image is molded.
- 2.The separation arraying conveyor can realize the orderly arrangement of products, high-speed and stable, and easy to operate.
- 3.The conveyor belt of automatic feeding system can disassemble and disassemble quickly without tools. The bottom and interface of conveyor belt are equipped with slag slot, which is convenient to maintain and clean equipment, save time and effort.
- 4.The whole line selects high-quality food grade conveyor belt.
- 5.Control system uses high-quality electrical components, equipped with servo motor, PLC control, touch screen operation display, good man-machine interface, simple operation, intuitive, convenient.

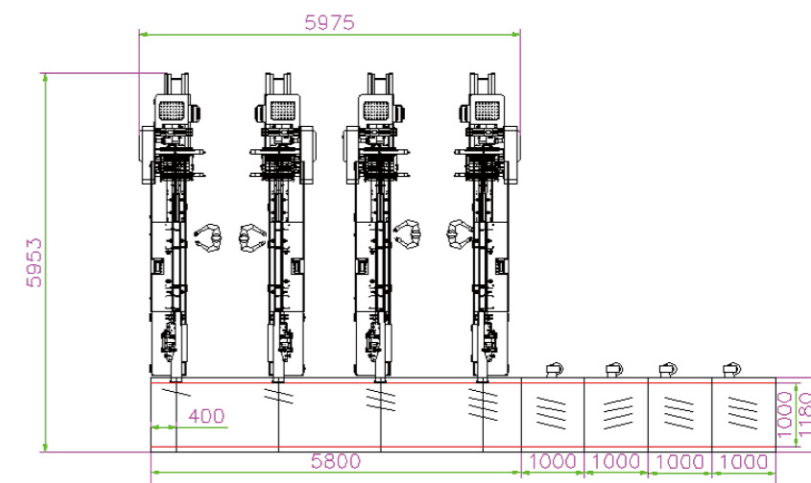

## 导购提示 GUIDE TO PURCHASE

1. 自动理料系统根据前端来料情况和包装要求来选型，来料情况包括：物料特性、加工工艺、产量、状态、排列方向等；包装要求包括：单个装、多个装、组合装、加托盒、分正反面等。
2. 根据不同理料系统稳定的运行速度匹配客户产能需求，设计科学合理高效的规划方案。

- 1.The automatic feeding system is selected according to the products incoming condition and the packaging requirements. Products incoming condition includes: material characteristics, processing technology, capacity, status, arrangement direction, etc. The packaging requirements includes: single, multi-pack assembly, adding support box, positive and negative, etc.
- 2.According to the stable operation speed of different feeding packing line, to match the demand of customer's production capacity, design the scientific, reasonable and efficient planning scheme.



## 设备优势 EQUIPMENT ADVANTAGE

1. 自动理料系统一般由物料整列（排）输送机、自动理料机组和自动包装机组成，不同类型的系统，有对应的备选功能，以满足客户的包装需求。
2. 理料单元单个物料的理料速度 100-600pcs/min(跟产品尺寸和状态有关)。
3. 理料单元功率约 1.2kW。

- 1.The automatic feeding system normal combined by separation arraying conveyor, automatic feeding system and automatic packing machine, different types of systems, with corresponding alternative functions to meet customer packaging needs.
- 2.The working speed of automatic feeding system is 100-600pcs/min by single kind product.
- 3.The automatic feeding system power is about 1.2kW.

# SWISS ROLL PACKING LINE

下沉式自动理料线

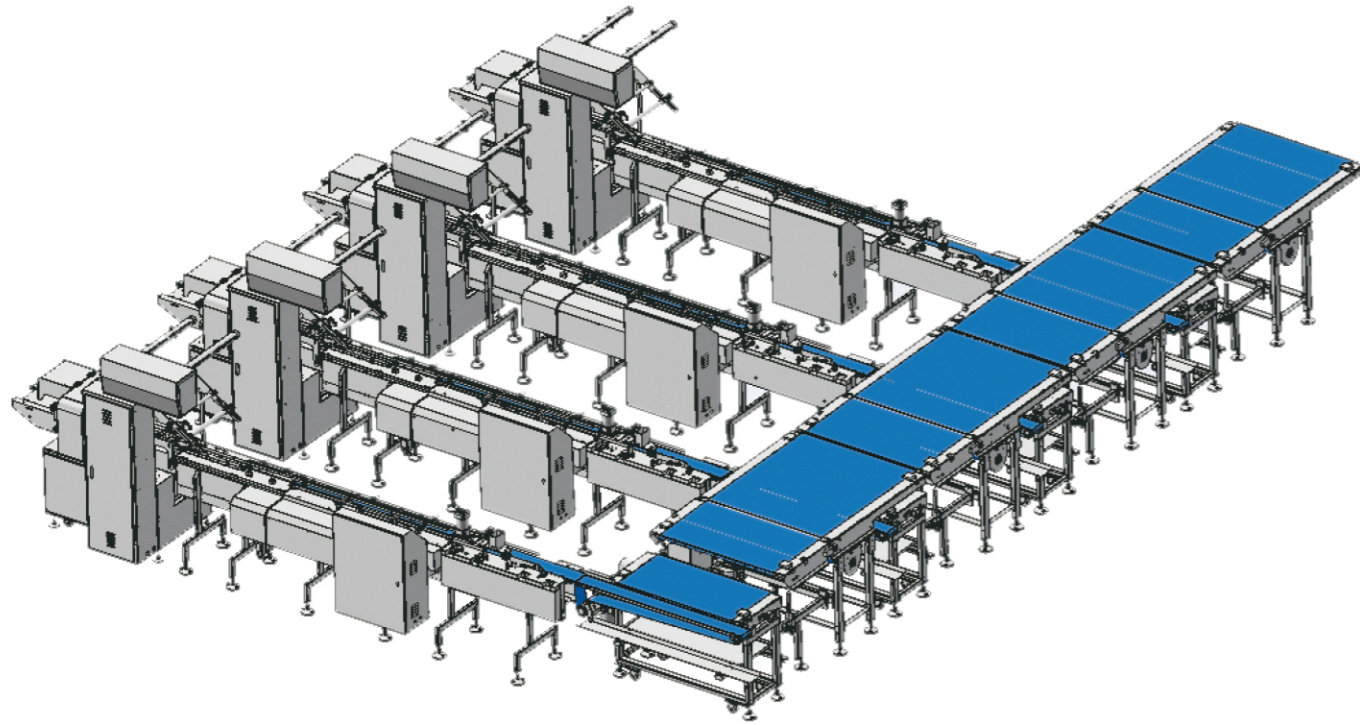

## 适用范围 APPLICATION SCOPE

下沉式自动理料线主要针对瑞士卷、夹层蛋糕、三角蛋糕等外形规则，前端来料整齐的产品。

The swiss roll packing line is mainly for products with regular shapes such as Swiss rolls, sandwich cakes, triangular cakes, etc., and the front-end materials are neatly received.

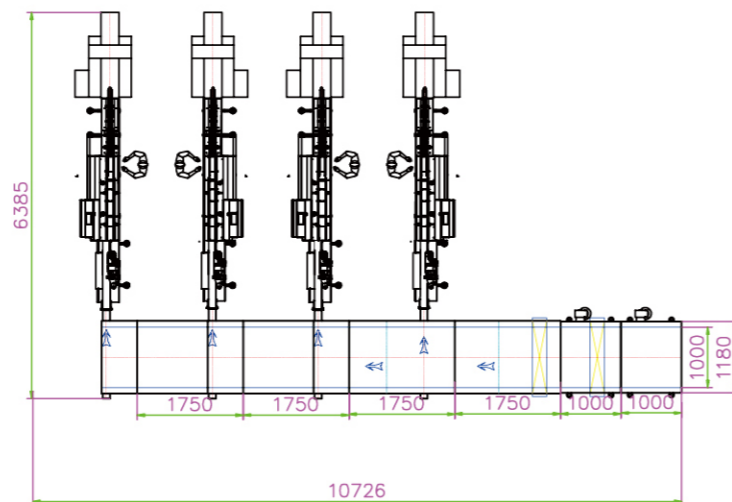

# UP-FEEDING PACKING LINE

上升式自动理料线

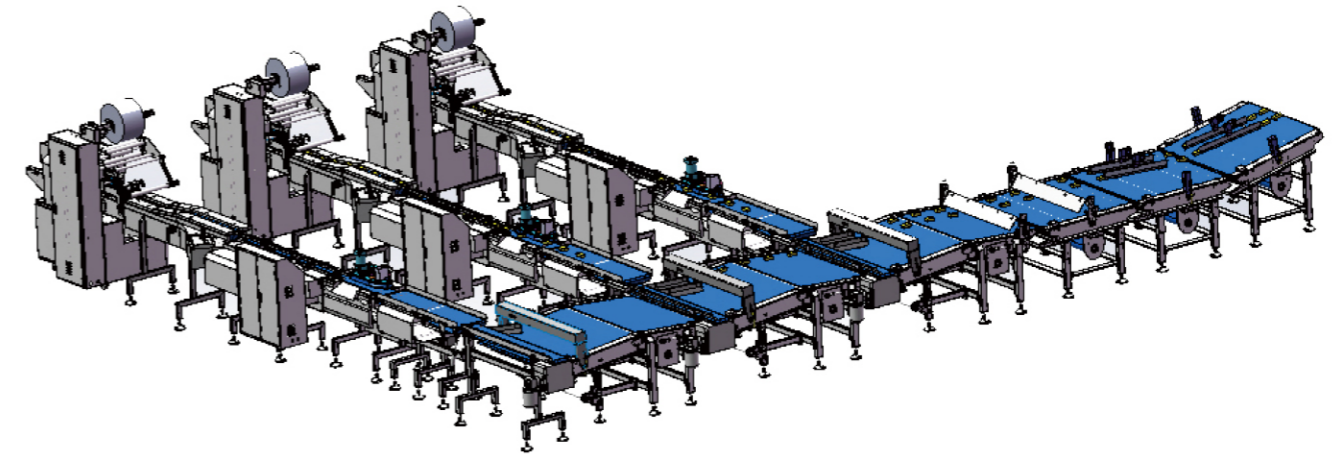

## 适用范围 APPLICATION SCOPE

上升式自动理料线主要针对沙琪玛、米花糖、蛋糕和威化饼等外形规则的产品。前端可对接生产线实现自动连续供料。

The up-feeding packing line is mainly for products with regular shapes such as shaqima, rice crackers, cakes and wafers. The front end can be connected to the production line to realize automatic continuous feeding.

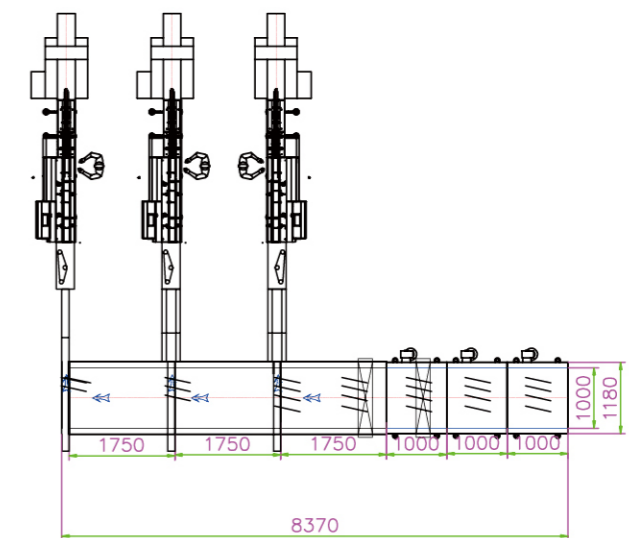

# CAKE BISCUIT PACKING LINE

## 整列式自动理料线

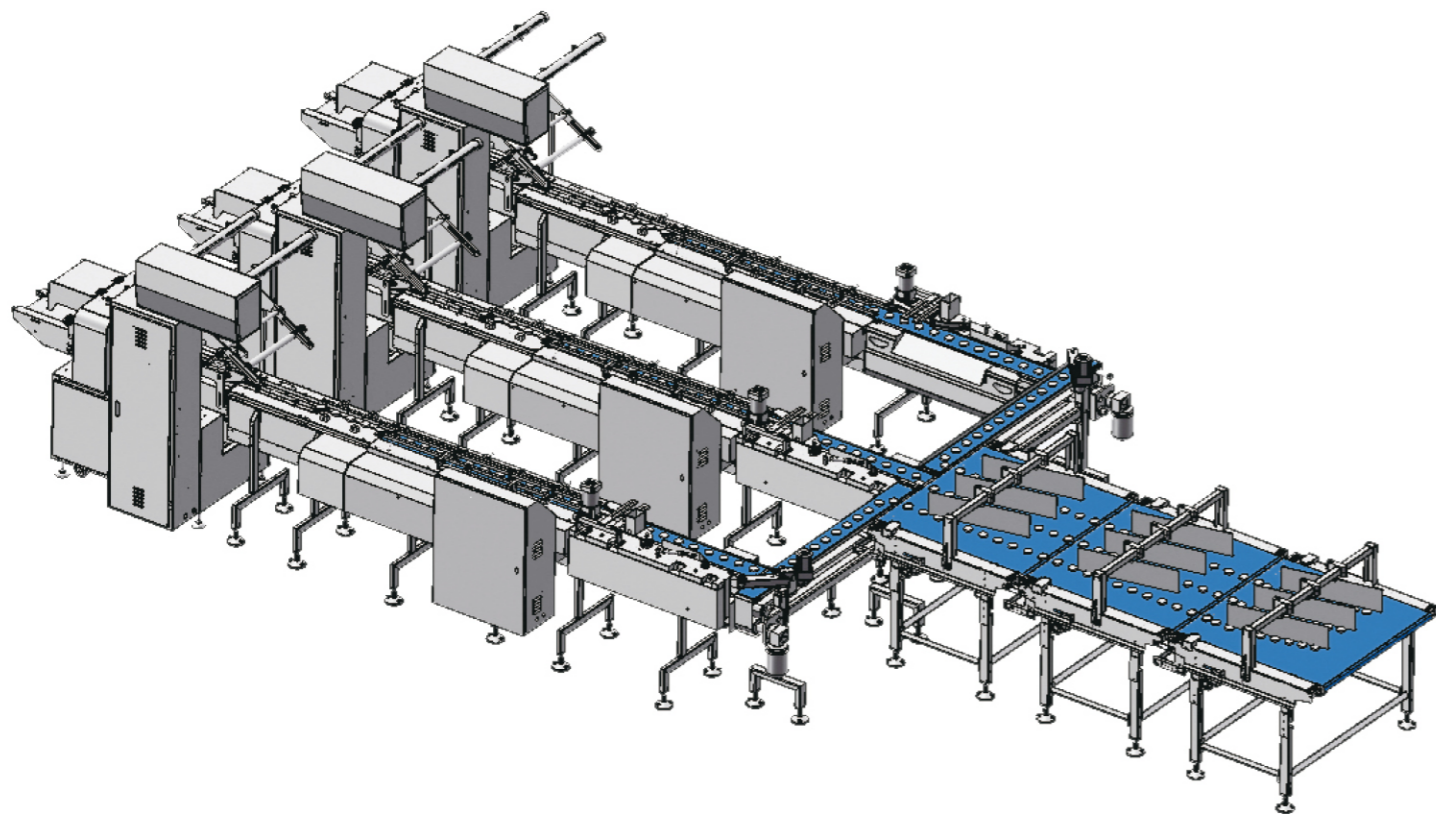

### 适用范围 APPLICATION SCOPE

整列式自动理料线主要针对蛋黄派、肉松饼、面包、磨堡蛋糕、金牌蛋糕类等外形规则的产品。

The cake biscuit packing line is mainly for products with regular appearances such as egg yolk pies, meat muffins, bread, mobao cakes, and gold medal cakes.

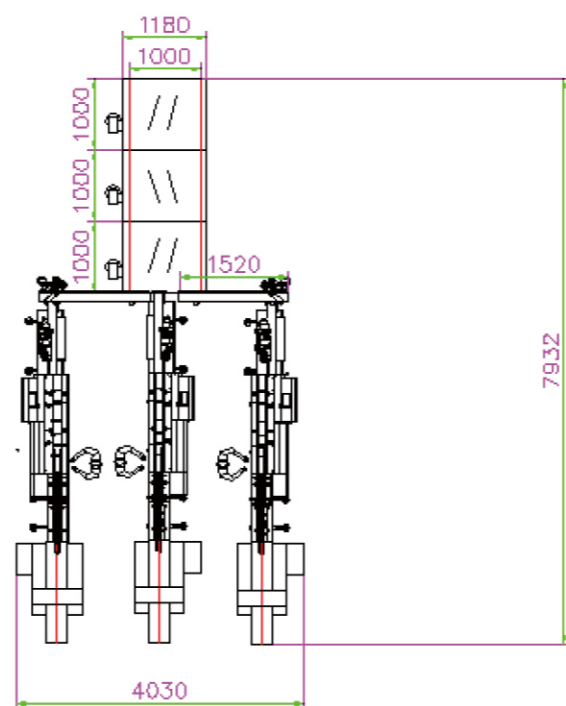

# WAFFER PACKING LINE

## L型自动理料线

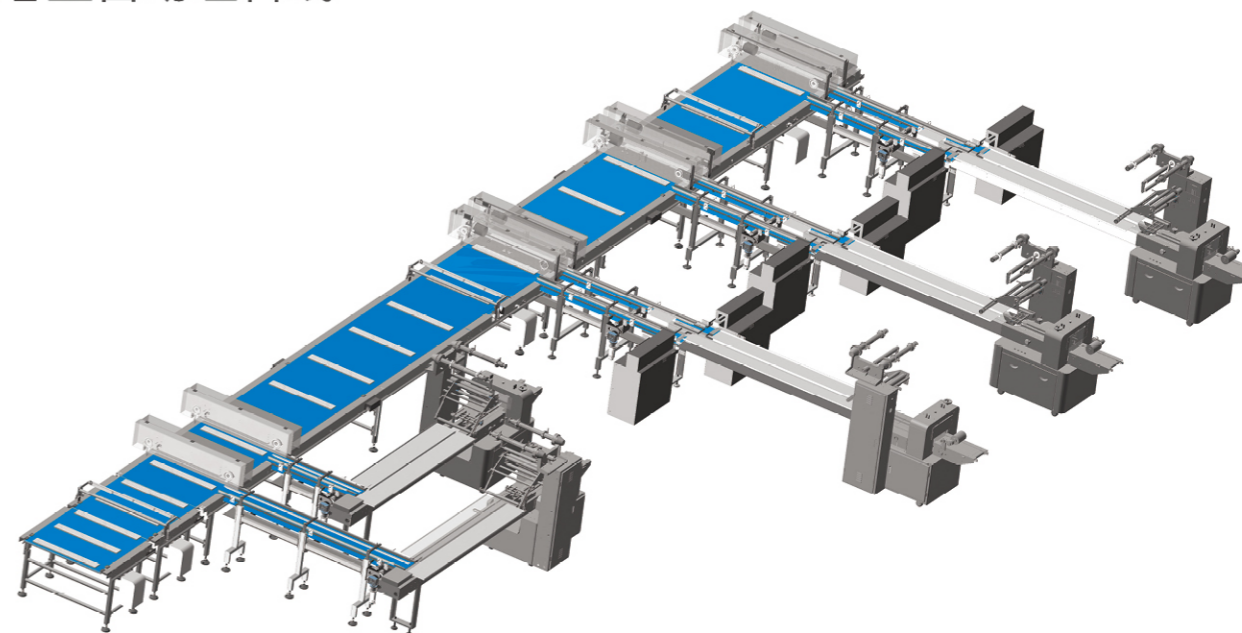

### 适用范围 APPLICATION SCOPE



L形自动理料线主要针对威化饼等切割类产品，其产量大、排列整齐、形状规则，解决了由于物料密集，传统理料方式不易拉开距离，转向难，不易排列等问题，实现单个或多个组合式包装。

Applicable for wafer and some other cutting products with large capacity, in good order, regular shape. Solve the problem of close distance, difficult turning, not easy to arrange of traditional feeding mode, to achieve single or multiple packaging form.

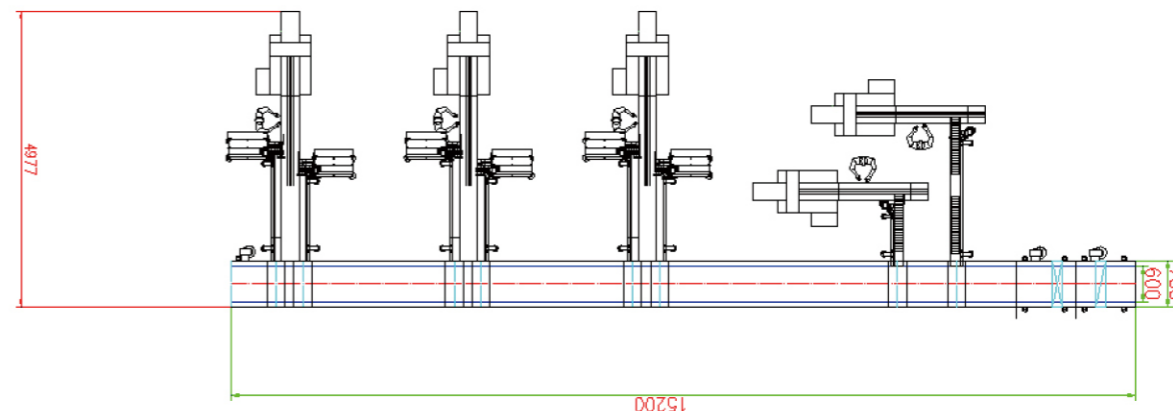

# RICE BAR PACKING LINE

## ▲ 圆盘自动理料线

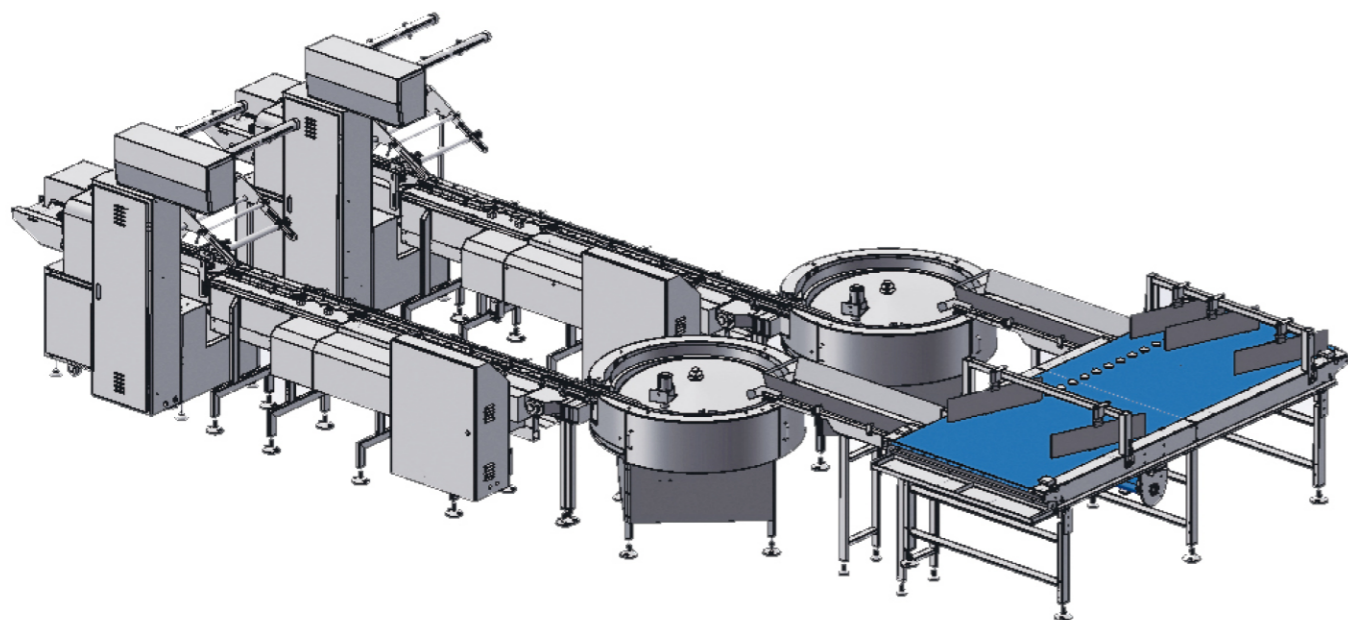

### 适用范围 APPLICATION SCOPE

圆盘自动理料线主要针对米果、棉花糖、燕麦巧克力、酥糖、松塔、果仁酥类等外形规则的产品。前端可对接生产线实现自动连续供料、也可人工上料。

The rice bar packing line is mainly for products with regular appearances such as rice crackers, marshmallows, oatmeal chocolate, flaky candies, pine cones, and pralines. The front end can be connected to the production line to realize automatic continuous feeding or manual feeding.

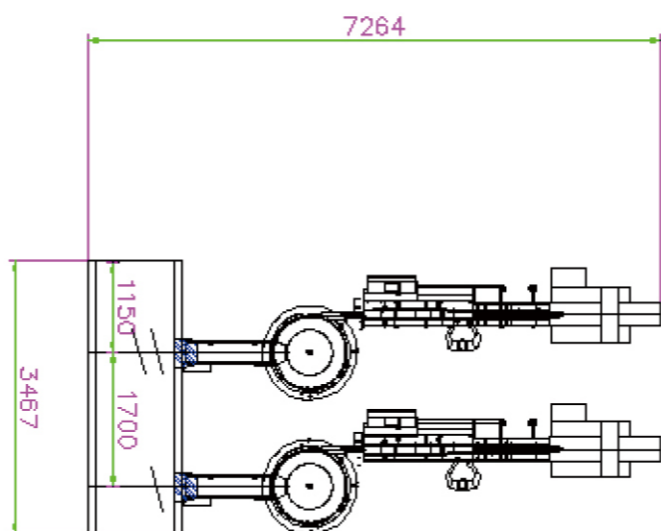

# CANDY PACKING LINE

## ▲ 高速自动理料线

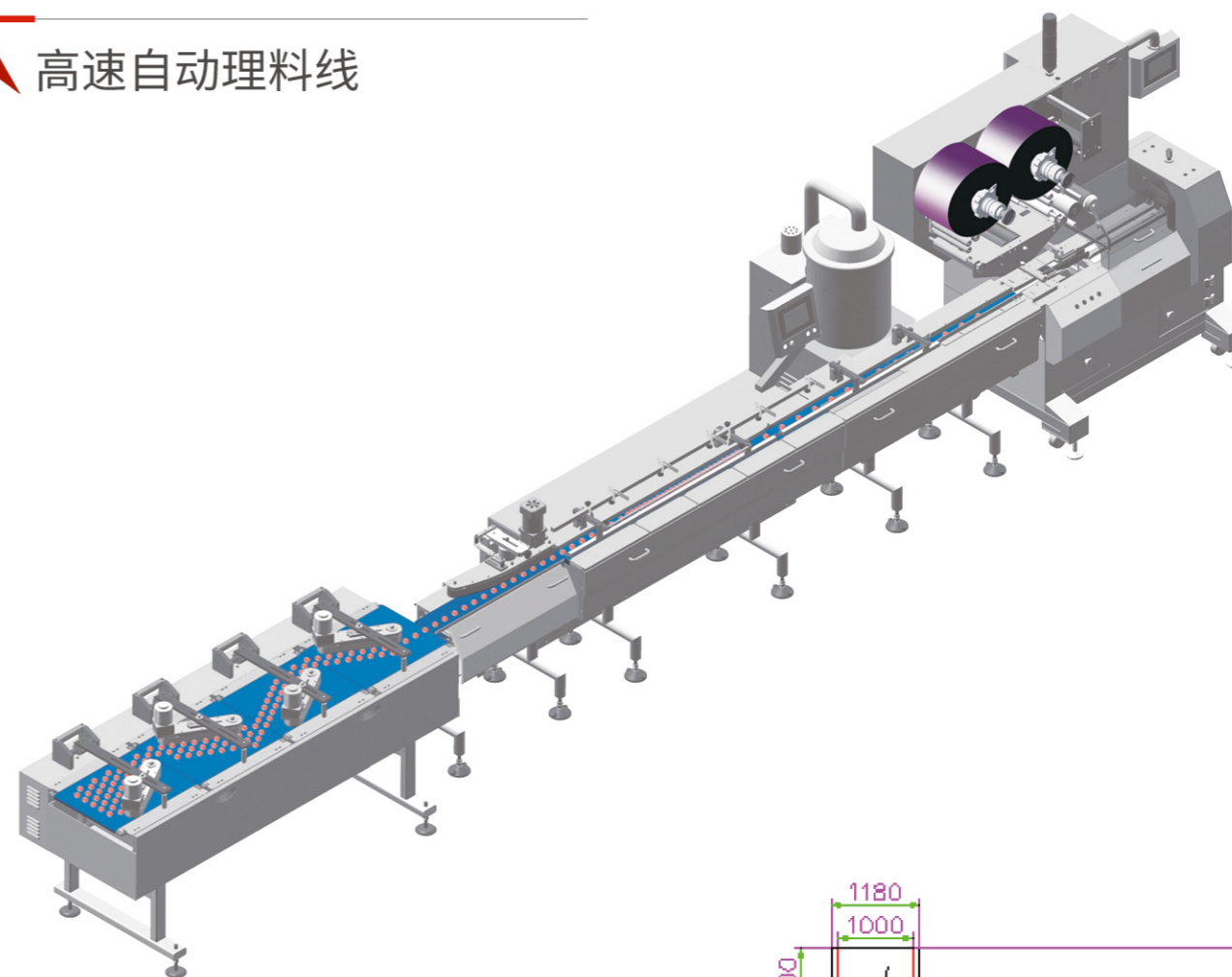

### 适用范围 APPLICATION SCOPE

高速自动理料线主要针对糖果、巧克力、饼干等外形规则的产品。前端可对接生产线，实现自动连续供料，也可人工上料。

Applicable for packing candy, chocolate, cookies and other regular shape objects. Connected with former production line by automatic feeder or manual feeder.

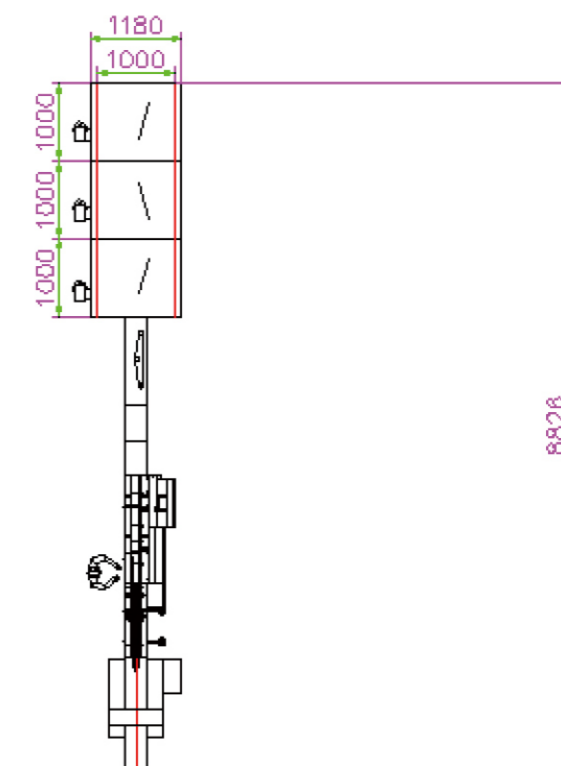

# TWO-CHANNEL AUTOMATIC PACKING LINE

## 双通道自动理料线

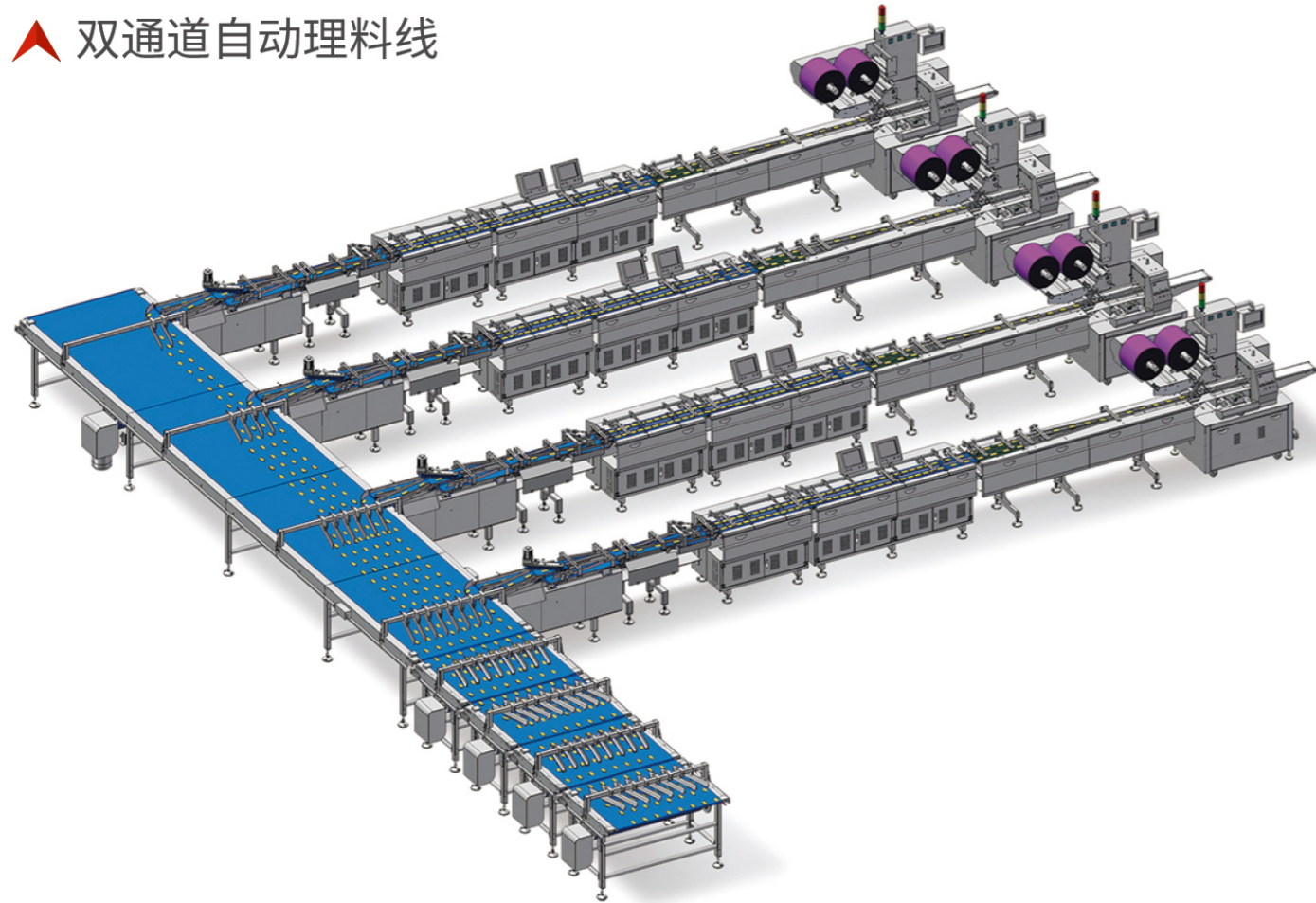

## 性能特点 PERFORMANCE CHARACTERISTICS

- 1、双通道自动理料线由拉距输送机、分配输送机、转向汇集机组、堆料输送机、双通道储料输送机、双通道自动理料机组、双通道叠层尾架以及自动包装机组成，对包装物进行拉距分列整理、自动分配，把产品有序送进多通道（双通道）自动理料机组进行定位包装。达到生产连续、高效、包装美观的效果。
- 2、可选配自动翻面装置，拉距输送机可视需要设计。
- 3、单条线包装速度可达 350 包 / 分钟，速度依产品尺寸、包装形式和包材而定。
- 4、整线采用 220V 50Hz 电源，如图所示，一拖四总功率约 42kW。

- 1.Two-channel automatic packing line consists of separating conveyor, distributing conveyor, tuning&collecting unit, stacking conveyor, two-channel storage conveyor, two-channel automatic feeding unit, two-channel stacking conveyor and automatic packing machine. The process is, first open products distance, divide into columns, then automatic distribute, finally feed the products into multiple channels(two channels) automatic feeding unit and packing machine. The advantage is continuous production, high efficiency and beautiful packaging.
- 2.Automatic tune-over device is optional. Separating conveyor can be designed according to the actual situation.
- 3.Maximum packing speed of single line can reach 350 bags/min. The actual speed depends on product dimension, packaging type and the material of packaging film.
- 4.Power supply adopts 220V 50Hz,total power is about 42kW as the drawing(4lines).

## 设备优势 EQUIPMENT ADVANTAGE

效率翻倍  
叠片：稳定速度 350 包 / 分钟 / 台

Double efficiency  
Overlaying: steady speed 350 bags/min/line

高速自动翻转  
针对有正反面产品

Automatic turning over at high speed.  
Distinguish top and bottom face of products.

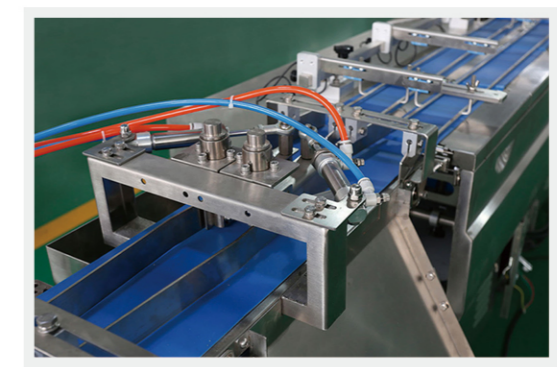
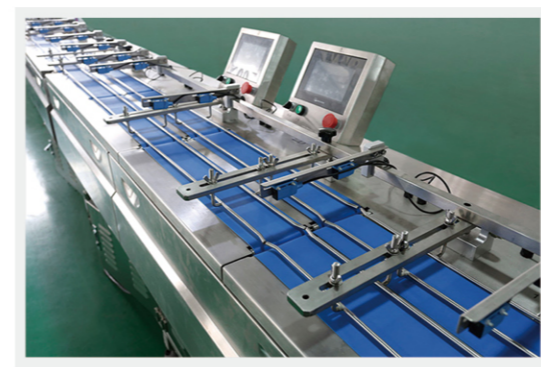

## 适用范围 APPLICATION SCOPE

双通道自动理料线适用于饼干、曲奇、华夫饼、仙贝等外形规则的产品。  
The Two-channel automatic packing line is suitable for biscuits, cookies, waffles, senbei, etc. Products with regular appearance.

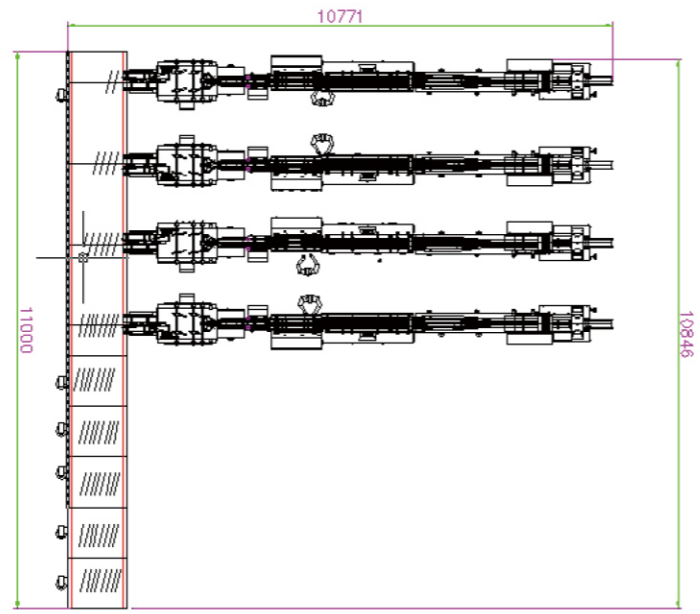

# EDGE BISCUITS PACKING LINE

## 无托自动理料线

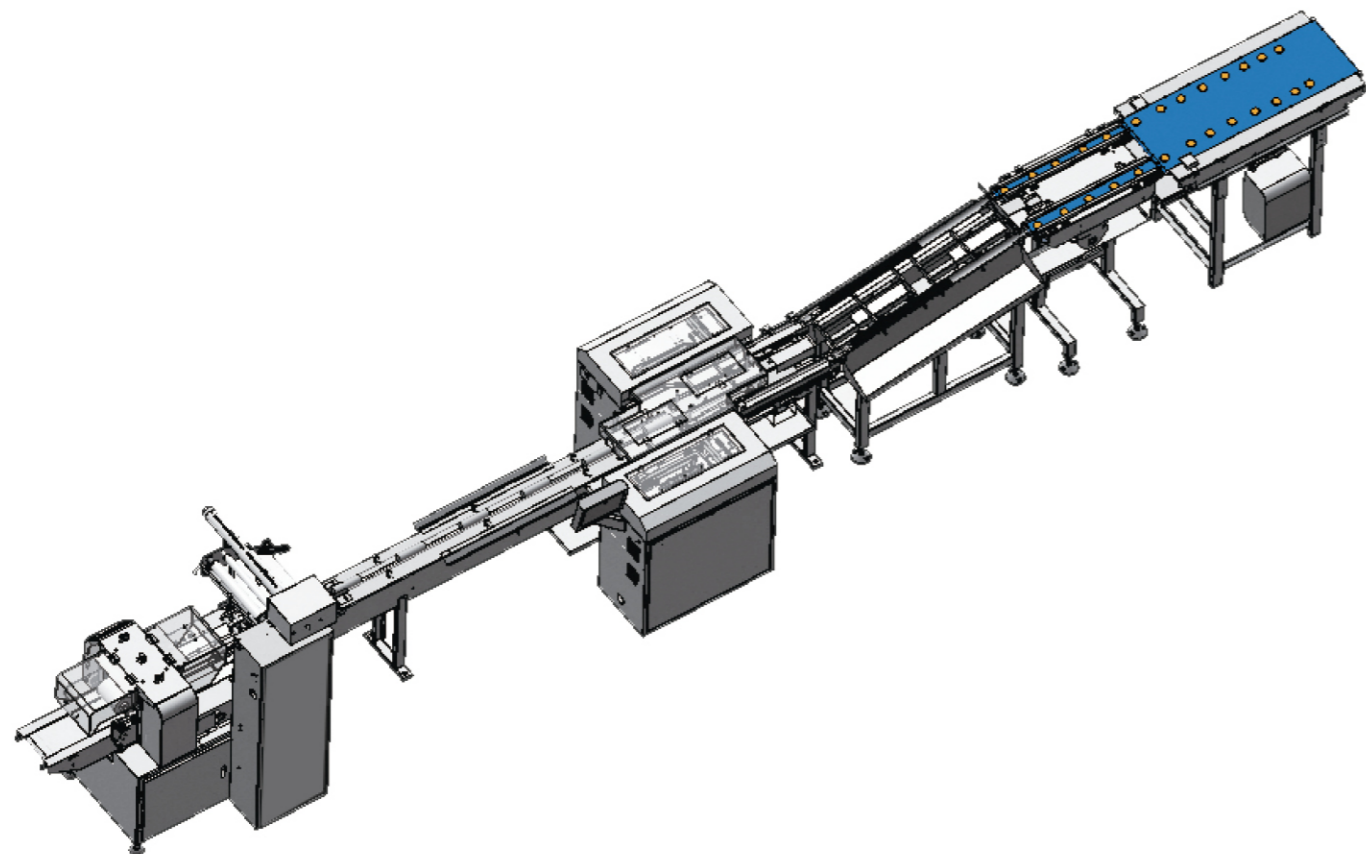

质量保障  
QUALITY ASSURANCE



精准操作  
PRECISE OPERATION



智能控制  
INTELLIGENT CONTROL



### 性能特点 PERFORMANCE CHARACTERISTICS

1. 无托自动理料线由分配整理输送机、振动输送机、双向推料机和无托包装机组成。
2. 单条线包装速度可达到 100 包 / 分钟（依产品尺寸和包装形式而定）。
3. 整线采用 220V 50Hz 电源，如图所示，总功率约 3.6kW（不含包装机）。

1. The edge biscuits packing line is composed of a distribution and sorting conveyor, a vibrating conveyor, a two-way pusher and a non-supporting packaging machine.
2. Single line packaging speed can reach 100 bags/min (depending on product size and packaging form)
3. The whole line adopts 220V 50Hz power supply, as shown in the figure, the total power is about 3.6kW (without packaging machine).



### 设备优势 EQUIPMENT ADVANTAGE

1. 饼干排列数量可依据包装要求设定调节。
2. 无托理料线采用双向推料，速度更高更稳定。
3. 输送稳定，速度均匀，饼干整体输送可靠性高。
4. 前端可对接生产线，实现自动供料，也可人工手动放料。

1. All of the biscuits can be set and adjusted according to the packaging requirements.
2. The non-supporting feeder adopts two-way push material, higher speed and more stable.
3. Stable conveying, uniform speed, high reliability of overall biscuit conveying.
4. The front end can be connected to the production line to comply automatic feeding or manual discharging.



### 适用范围 APPLICATION SCOPE

无托自动理料线针对饼干类（不夹心）多片排列包装的产品，前端可对接生产线，实现多线分配输送，经振动整理，堆叠后送入无托包装机。

For multi-piece biscuit packing products (non-sandwich), The front end can be docked with the production line comply multi-line distribution and conveying, after being sorted by vibration, stacked and sent to the non-pallet packaging machine.

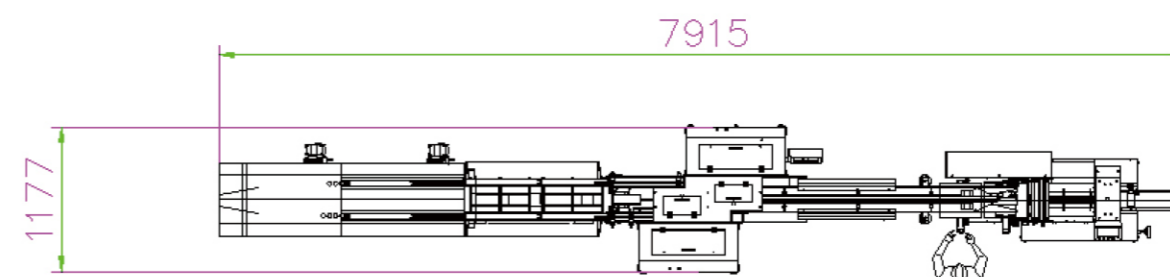

# BISCUIT AUTOMATIC COUNTING AND PACKING LINE

## 可计数自动理料线



质量保障  
QUALITY ASSURANCE



精准操作  
PRECISE OPERATION



智能控制  
INTELLIGENT CONTROL

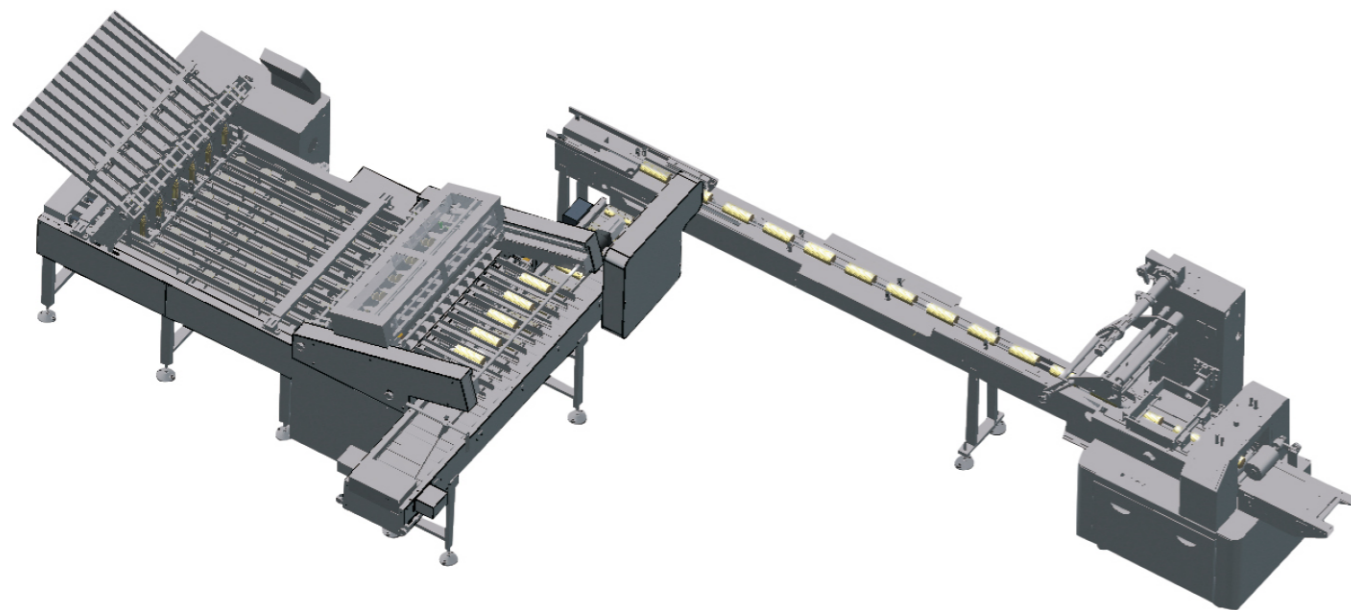

## 性能特点 PERFORMANCE CHARACTERISTICS

1. 可计数自动理料线由供料输送机、计数整理机、横向接料输送机以及自动包装机组成，对圆形或方形饼干产品进行精确计数整理，将产品有序定位，送进包装机。达到生产连续，废品率低，包装美观的效果。
2. 六通道理料线速度可达到 80 包 / 分钟（依产品尺寸和包装形式有不同）。
3. 整线采用 220V 50Hz 电源，如图显示，一拖一（六通道）总功率约 8.3kW。

1. The biscuit counting and packing line is composed of a feeding conveyor, a counting and sorting machine, a transverse receiving conveyor and an automatic packaging machine, which accurately counts and arranges round or square biscuits, positions the products in an orderly manner, and sends them to the packaging machine. It can achieve the effect of continuous production, low rejection rate and beautiful packaging.
2. The speed of 6-channel machine can reach 80 bags/min (depend on product size and packaging form).
3. The whole line uses 220V 50Hz power supply, as shown in the figure, the total power of one packing line (six channels) is about 8.3kW.

## 设备优势 EQUIPMENT ADVANTAGE

1. 采用六通道饼干可计数自动理料线同时对产品进行整理、计数、排列、定位，高速、高效。
2. 前端可对接不同生产线实现自动连续供料，针对夹心饼干可准确计数。

1. Six-channel biscuit counting device is used to sort, count, arrange, and position the products at the same time, high-speed and efficient.
2. The front end can connect to different production lines to realize automatic and continuous feeding, also suitable for sandwich biscuits.

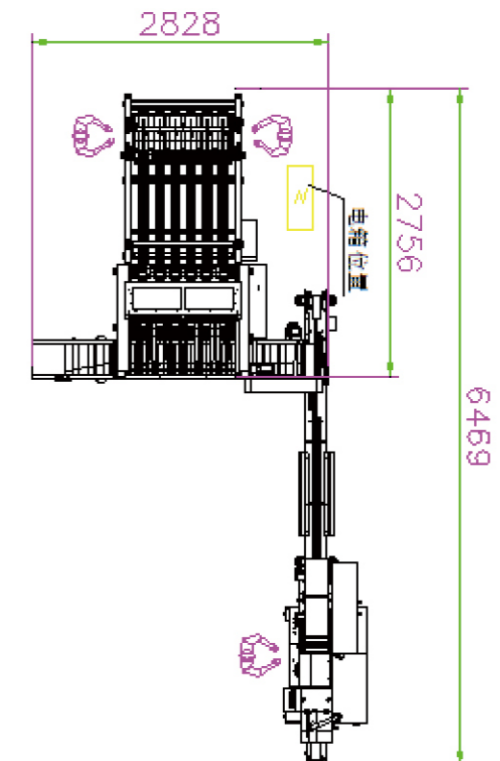

## 适用范围 APPLICATION SCOPE

可计数自动理料线主要针对圆形或方形饼干产品，精确计数，进行无托或带托包装。前端可对接不同生产线实现自动连续供料。

The biscuit counting and packing line is mainly for round or square biscuits, accurate counting, it can realize packages without tray or with tray. The front end of this packing line can connect to different production lines to realize automatic continuous feeding.







# AUTOMATIC TRAY LOADING PACKING LINE

## 自动装托理料线



质量保障  
QUALITY ASSURANCE



精准操作  
PRECISE OPERATION



智能控制  
INTELLIGENT CONTROL

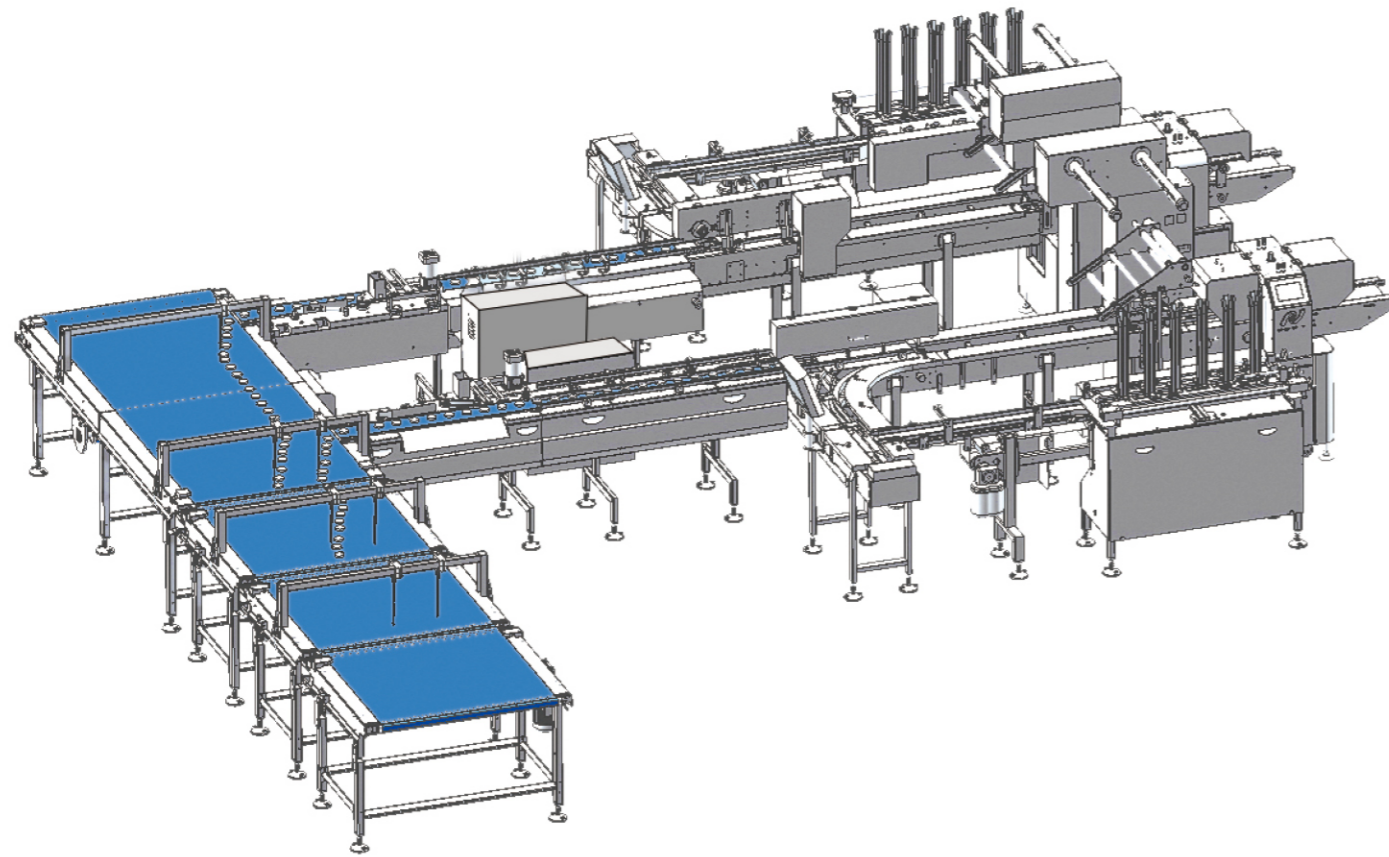

### 性能特点 PERFORMANCE CHARACTERISTICS

1. 自动装托理料线由拉距输送机、分配输送机、自动理料机组、分托机构、入托机构及自动包装机组成，对月饼等产品进行拉距整理、分配输送、定位，对托盒自动分托、排列，在汇合处将产品准确送入托盒，进行包装。同时可同步投放脱氧剂或酒精片。
2. 单条线包装速度可达 200 包 / 分钟（依产品和包装形式而定）。
3. 整线采用 220V 50Hz 电源，如图所示：一拖二总功率 13kW。

- 1.The automatic tray loading packing line is composed of a stretch conveyor, a distribution conveyor, an automatic sorting unit, a sub-supporting mechanism, a feeding mechanism and an automatic packaging machine. It performs stretch sorting, distribution, transportation, and positioning of moon cakes and other products, and pallets Automatically divide and arrange the products, and accurately deliver the products into the pallet at the meeting point for packaging. At the same time, deoxidizer or alcohol tablets can be added simultaneously.
- 2.The packaging speed of a single line can reach 200bags/min (depending on product size and packaging form).
- 3.The whole line adopts 220V 50Hz power supply, as shown in the figure: the total power of one to two is 13kW.



### 设备优势 EQUIPMENT ADVANTAGE

1. 自动分托机构将托盒自动分开，稳定连续，实现自动化生产，提高食品安全性及效率，通过自动投包机同步投放脱氧剂或酒精片。
2. 多段差速整理物料，实现物料稳定高速，定位精确。

- 1.the trays automatically, stably and continuously, realizes automatic production, improves food safety and efficiency, and simultaneously puts deoxidizer or alcohol tablets through the automatic feeding machine.
- 2.Multi-stage differential sorting of materials to achieve stable and high-speed materials and accurate .

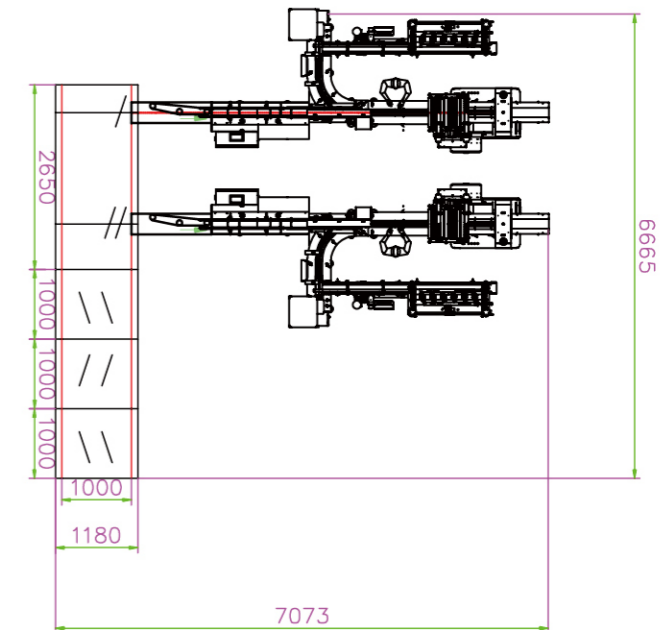

### 适用范围 APPLICATION SCOPE

自动装托理料线主要针对月饼、肉松饼、蛋糕类等外形规则及需带托包装的产品。前端可对接生产线实现自动连续供料、也可人工上料。

Applicable for packing moon cake,shredded pork waffle, cake and other regular shape objects with tray/box.Connected with former production line by antomatic feeder or manual feeder.



# MULTI-CHANNEL TRAY LOADING PACKING LINE

## 多通道装托理料线

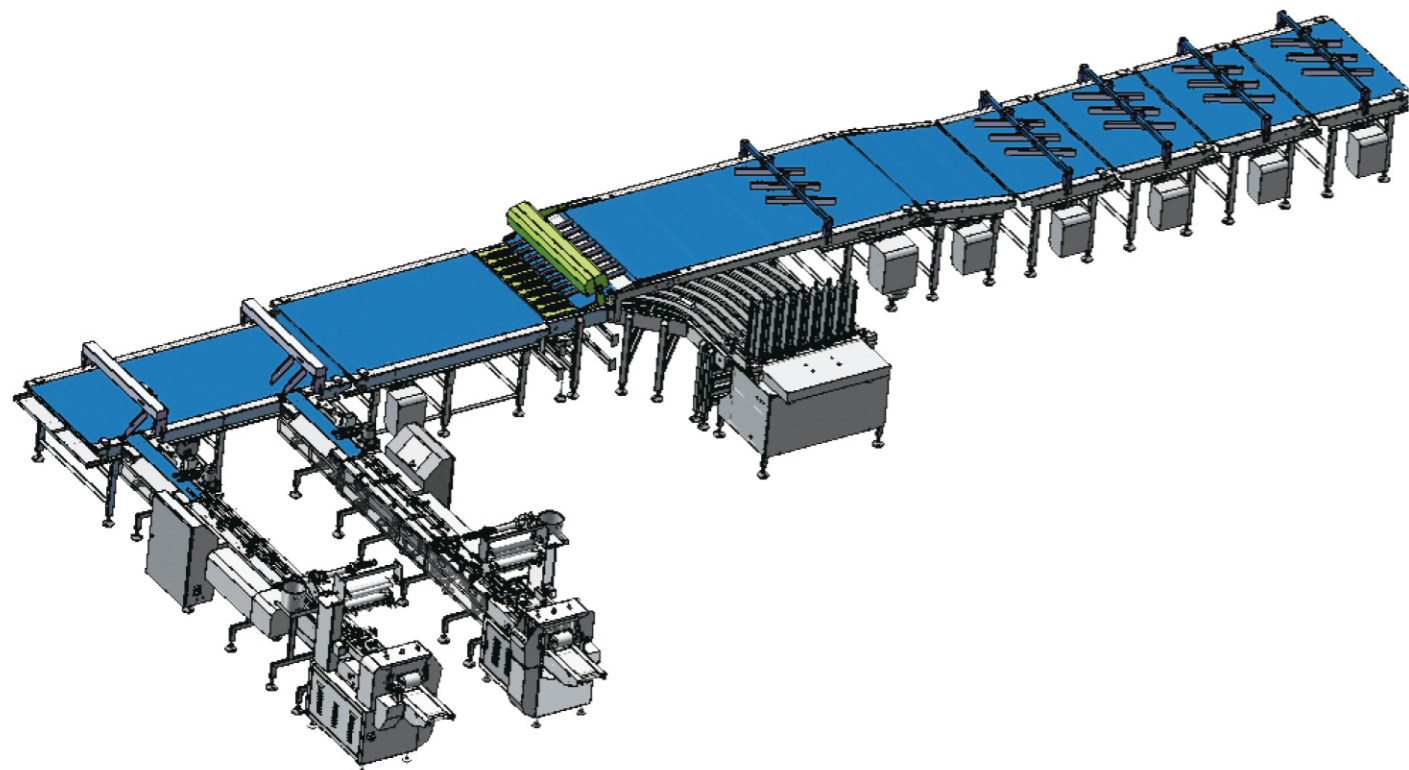

质量保障  
QUALITY ASSURANCE



精准操作  
PRECISE OPERATION



智能控制  
INTELLIGENT CONTROL



### 性能特点 PERFORMANCE CHARACTERISTICS

1. 多通道装托理料线由拉距输送机、自动分托机、转弯送托机、自动装托机、分配输送机、自动理料机组及自动包装机组成，对饼干等产品进行拉距分列整理，自动分配，自动装托，可实现单片、多片、单层、多层等多种装托形式，达到生产连续，速度快，产能大的效果。
2. 单条装托通道理料速度可达到 120 片 / 分钟（依产品尺寸和包装形式有差异）。
3. 整线采用 220V 50Hz 电源，如图所示，一拖二（八装托通道）总功率约 9kW（不含包装机）。

1. The multi-channel tray loading packing line is composed of separating conveyors, automatic tray separating machine, tray feeding conveyor, automatic loading into tray machine, distributing conveyor, automatic feeding line and automatic packaging machine, which are used to pull away products, automatic distribution, automatic loading into tray, realize single-package, multi-package, single-layer, multi-layer and other types of loading forms, to achieve continuous production, high speed, and large capacity.
2. The speed of a single line loading tray can reach 120 pieces/min (depending on product size and packaging form).
3. The whole line uses 220V 50Hz power supply, as shown in the figure, the total power of one to two (eight channels) is about 9kW (not including the packaging machine).



### 设备优势 EQUIPMENT ADVANTAGE

1. 分托机、转弯送托机和装托机中各通道采用独立气缸和伺服电机控制，装托定位精确，高速稳定。
2. 可实现单片、多片、单层、多层等多种装托形式，高速高效，产能大，省人省力。
3. 装托完成后经光电检测，在分配输送机上依次放行各通道产品，托盒理料稳定性高。

1. Separating tray machine, tray feeding conveyor and loading into tray machine are controlled by independent cylinders and servo motors. Tray positioning is accurate, high-speed and stable.
2. It can realize single-package, multi-package, single-layer, multi-layer and other packaging forms, high-speed and high-efficiency, large output, and labor-saving.
3. After tray-loading is completed, the products in each channel will be released on the distribution conveyor by photoelectric detection, high stability of tray feeding and packing.

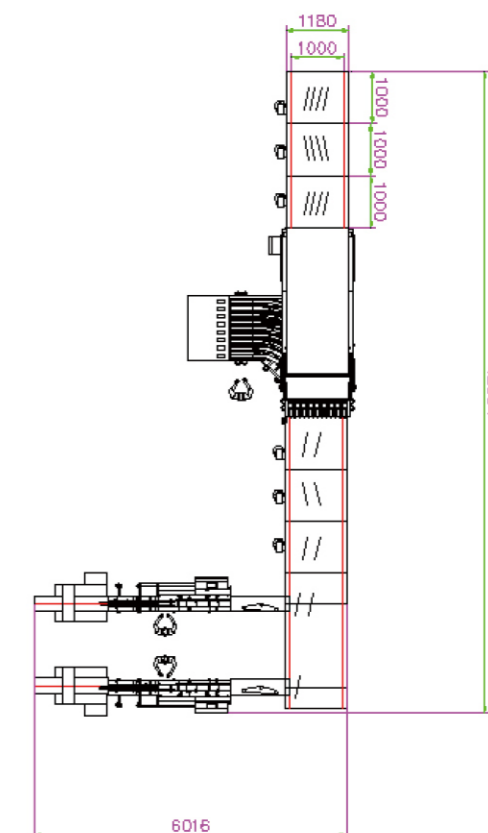

### 适用范围 APPLICATION SCOPE

多通道装托理料线针对饼干类产品进行单片、多片自动装托包装，前端可对接生产线实现自动连续供料，自动叠层，自动装托，完成多种包装形式。

Scope of application: for biscuit products, single and multi-piece automatic feeding into tray and packaging, the front end can connect to biscuit production line to realize automatic continuous feeding, automatic stacking, and automatic feeding into tray to complete a variety of packaging forms



# MULTI-BREAD LOADING WITH TRAY PACKING LINE

## 多枚装托自动理料线



质量保障  
QUALITY ASSURANCE



精准操作  
PRECISE OPERATION



智能控制  
INTELLIGENT CONTROL



### 性能特点 PERFORMANCE CHARACTERISTICS

1. 多枚装托自动理料线由拉距整列输送机、自动理料机组、伺服收料机组、自动拨料机、双通道汇合机组和自动包装机组成。面包由冷却塔出来后，经过拉距整列输送机拉开距离，自动理料机组有序排列，送入伺服收料机组，面包站立排列。在拨料机构的作用下，经上方通道送入托盒中。两条通道产品经过汇合，有序送入包装机进行包装。
2. 双通道理料包装速度 65 包 / 分钟（5 枚装托）。
3. 整线采用 220V 50Hz 电源，如图所示，总功率 12kW（含包装机）。

1. The multi-bread loading with tray packing line for multiple breads is composed of a stretch conveyor, an automatic sorting unit, a servo receiving unit, an automatic feeding machine, a dual-channel converging unit and an automatic packaging machine. After the bread comes out of the cooling tower, the automatic sorting unit is arranged in an orderly manner, and the bread is arranged in a standing position after passing through the distance of the entire conveyor. Under the action of the material shifting mechanism, it is sent into the pallet via the upper channel. After the two channels are merged, the products are sent to the packaging machine for packaging in an orderly manner.
2. The dual-channel material sorting and packaging speed is 65 bags/min (5 pieces pallet).
3. The whole line adopts 220V 50Hz power supply, as shown in the figure, the total power is 12kW (including packaging machine)

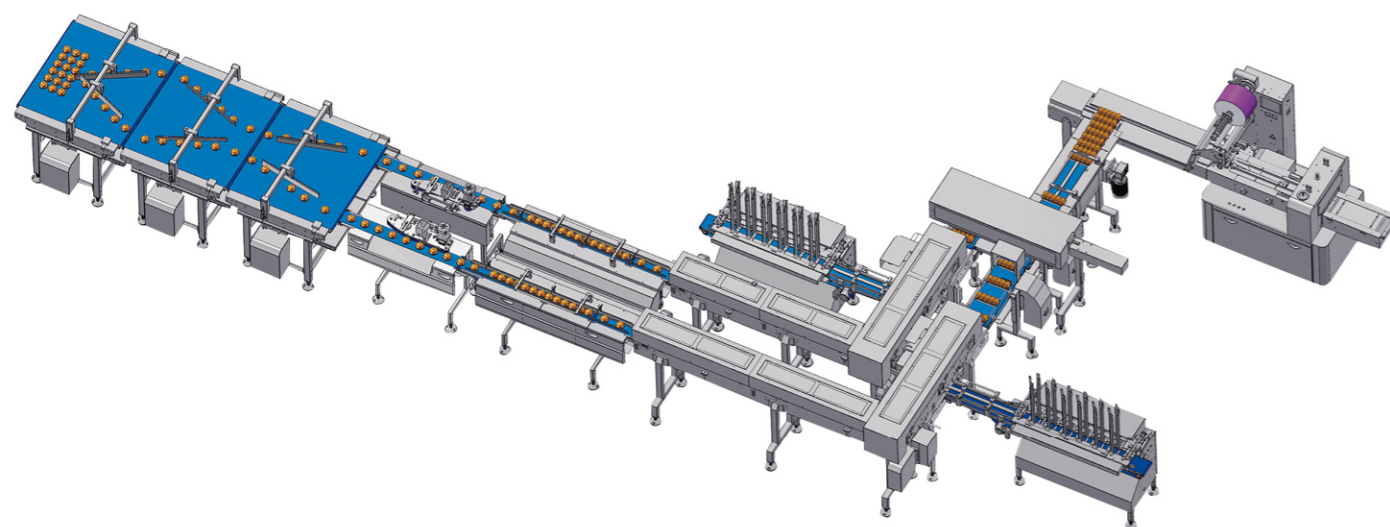

### 设备优势 EQUIPMENT ADVANTAGE

1. 面包生产线量大且生产不间断，多枚装托传统方式为人工装托，耗费大量劳动力。多枚装托自动理料线实现了智能机器自动装托，解放了大量劳动力，减轻了劳动强度。
2. 伺服收料机组的产品，经拨料机构送入装托通道，实现产品平稳装托，定位精确，稳定生产。产品在通道内有序站立排列运行，相关结构国内首创。

1. The bread production line is large in volume and uninterrupted in production. The traditional method of multiple pallets is manual pallet, which consumes a lot of labor. Multiple bread automatic loading and unloading lines realize automatic loading of intelligent machines, liberating a large amount of labor and reducing labor intensity.
2. The products of the servo rewinding unit are fed into the pallet channel via the feeding mechanism to realize stable palletizing, precise positioning and stable production. The products run in an orderly arrangement in the aisle, and the relevant structure is the first in China.

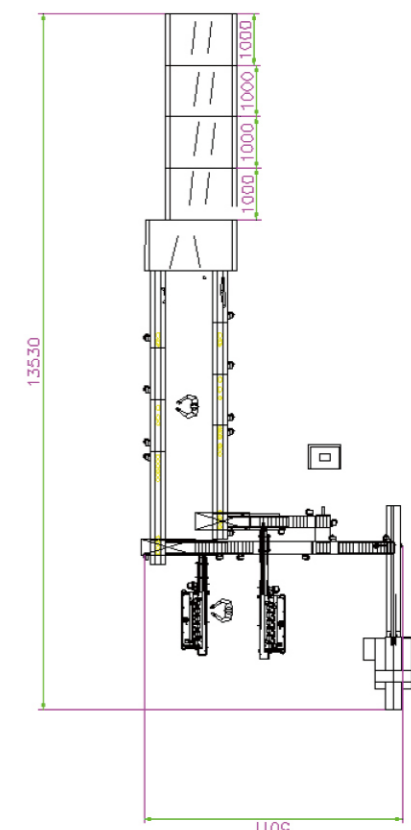

### 适用范围 APPLICATION SCOPE

多枚装托自动理料线主要针对面包等产量大、形状规则的产品，解决了产品站立排列，自动装托的问题。

The multi-bread loading with tray packing line is mainly for bread and other products with large output and regular shapes, which solves the problem of standing arrangement and automatic loading of products.



# HAMBURGER PACKING LINE

## 多排多列自动理料线

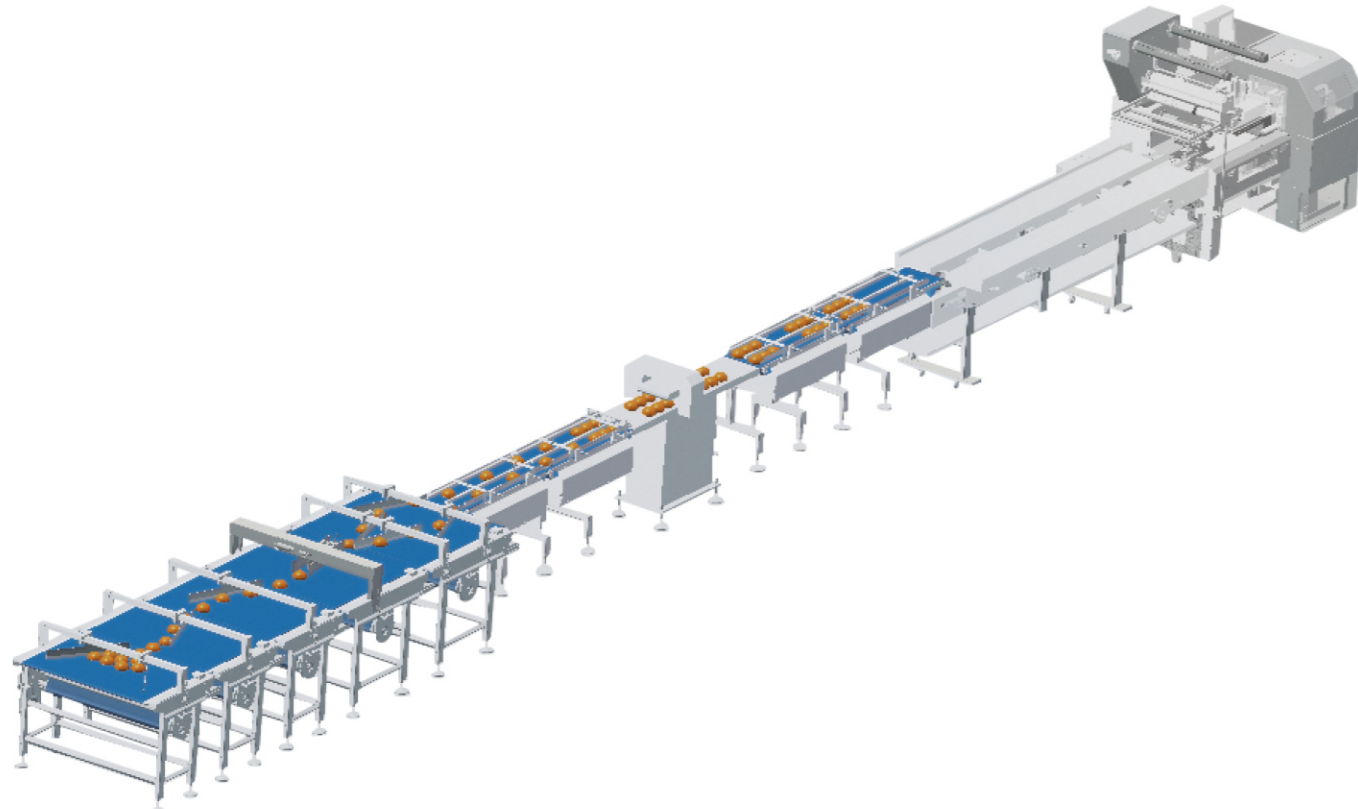

质量保障  
QUALITY ASSURANCE



精准操作  
PRECISE OPERATION



智能控制  
INTELLIGENT CONTROL



### 性能特点 PERFORMANCE CHARACTERISTICS

1. 多排多列自动理料线由拉距输送机、理料机组以及自动包装机组成，对圆形面包等产品进行拉距和均分整理。经过光电检测，控制理料机组和挡料机构，按设定数量排列组合，进入自动包装机进行包装，达到生产连续、有序、废品率低、包装美观的效果。
2. 单条线包装速度 30-40 包 / 分钟（根据产品组合方式有差异）。
3. 整线采用 220V 50Hz 电源，如图显示，一拖一总功率约 6.3kW（不含包装机）。

1. The hamburger packing line is composed of a stretch conveyor, a sorting unit and an automatic packaging machine, which stretches and evenly sorts round bread and other products. After photoelectric detection, control the sorting unit and the blocking mechanism, arrange and combine according to the set number, enter the automatic packaging machine for packaging, and achieve the effect of continuous, orderly production, low rejection rate and beautiful packaging.
2. The packaging speed of a single line is 30-40 bags/min (different according to the product combination).
3. The whole packaging line adopts 220V 50Hz power supply, as shown in the figure, the total power of one drag and one is about 6.3kW (not including packaging machine).



### 设备优势 EQUIPMENT ADVANTAGE

1. 多排多列自动理料线输送平台配置产品均分装置，保证各通道产品数量均匀。
2. 多段差速拉距整理，实现物料平稳输送，定位精准，高速稳定。

1. The conveyor platform of the hamburger packing line is equipped with a product equalization device to ensure that the number of products in each channel is even.
2. Multi-segment differential speed pulling distance arrangement realizes stable material conveying, precise positioning, high speed stability.



### 适用范围 APPLICATION SCOPE

多排多列自动理料线主要适用于圆形面包多排多列的包装形式。前端可对接生产线实现自动连续供料，也可人工上料。

The hamburger packing line is mainly suitable for the packaging of round bread with multi-row multi-line. The front end can be connected to the production line to realize automatic continuous feeding or manual feeding.

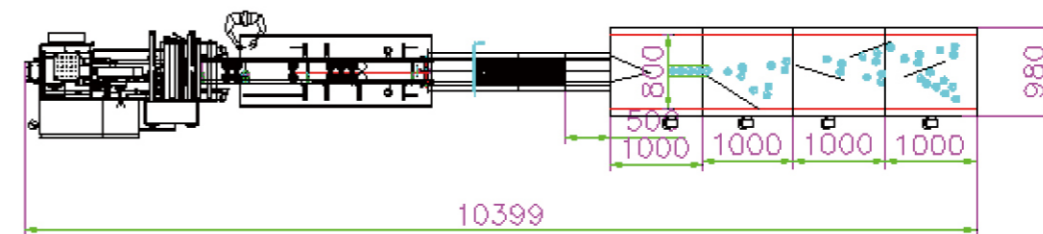

## COMBINED PACKING LINE SERIES

### 组合式包装理料线

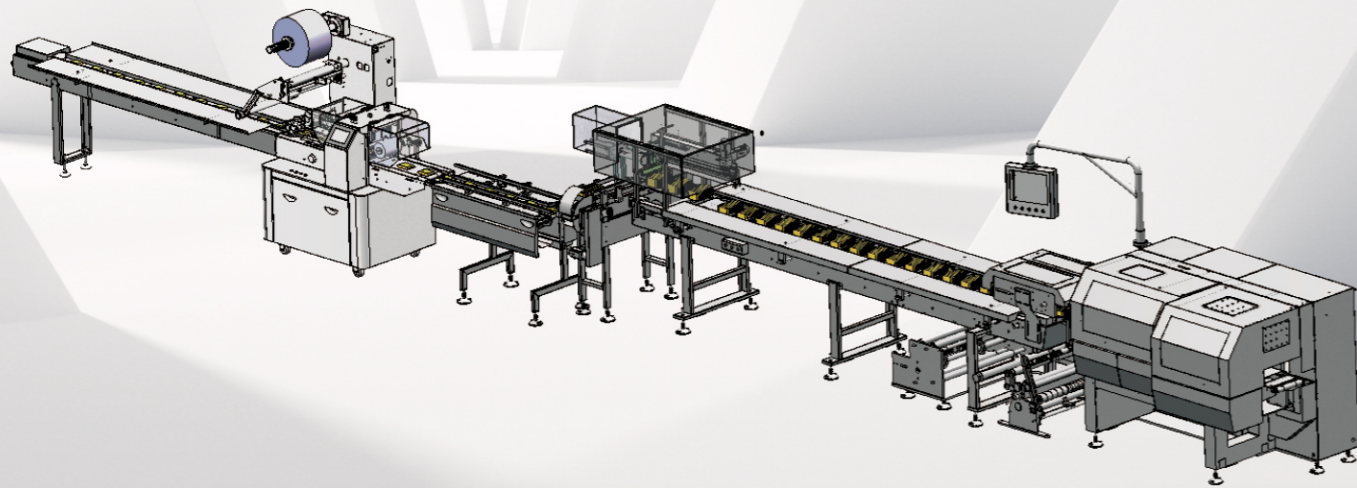

### 适用范围 APPLICATION SCOPE

组合式包装理料线主要针对产品的二次包装，实现产品多排多列的包装方式。前端可对接多台枕式包装机或生产线，实现自动连续供料。

The combined packing line is mainly for the secondary packaging, it can realize the packaging form in multiple rows and columns. The front end can connect with multiple sets of pillow packaging machines or production lines to realize automatic continuous feeding.



质量保障  
QUALITY ASSURANCE



精准操作  
PRECISE OPERATION



智能控制  
INTELLIGENT CONTROL



### 性能特点 PERFORMANCE CHARACTERISTICS

1. 组合式包装理料线由自动包装机组、过渡输送机、伺服收料机组以及下走纸往复式包装机组成，对前端单个包装好的产品按实际需求进行排列收集汇合，准确送入下走纸往复式包装机。达到生产连续，高速高效，省人省力的效果。
2. 下走纸往复式包装机速度可达到 40-60 包 / 分钟（依产品尺寸和包装形式有差异）。
3. 整线采用 220V 50Hz 电源。

1. The combined packing line is composed of automatic packaging machine unit, transition conveyor, servo receiving unit and down film-feeding reciprocating packaging machine. The packaged products at the front end are arranged and collected according to actual needs, and then accurately sent to reciprocating packaging machine. It can achieve continuous production, high speed, high efficiency, and labor saving.
2. The speed of reciprocating packaging machine can reach 40-60 bags/min (depending on product size and packaging form).
3. The whole line adopts 220V 50Hz power supply.



### 设备优势 EQUIPMENT ADVANTAGE

1. 采用双伺服收料系统，对单个包装产品准确收集、排列、定位送入下走纸往复式包装机。
2. 前端可对接多台枕式包装机或生产线，实现自动连续供料。
3. 可实现多排多列不同形式包装，参数调整方便快捷。
4. 整体结构简洁、操作简单、清洁方便、维护便捷。
5. 控制系统采用高品质电器元件，智能 PLC 控制，触摸屏显示，良好的人机界面，操作简单、直观、方便。

1. Double-servo receiving system is used to accurately collect, arrange, and position single packaged products and feed them into reciprocating packaging machine.
2. The front end can connect with multiple sets of pillow packaging machines or production lines to realize automatic continuous feeding.
3. It can realize multi-row and multi-column packaging in different forms, and parameter adjustment is convenient and quick.
4. Overall structure is simple, easy to operate, clean and maintain.
5. Control system adopts high-quality electrical components, intelligent PLC control, touch screen display, good man-machine interface, simple, intuitive and convenient operation.

# AUTOMATIC BAGGING AND PACKING MACHINE SERIES

## 自动套袋包装机



DKD60 直线进料

DKD60A 垂直进料

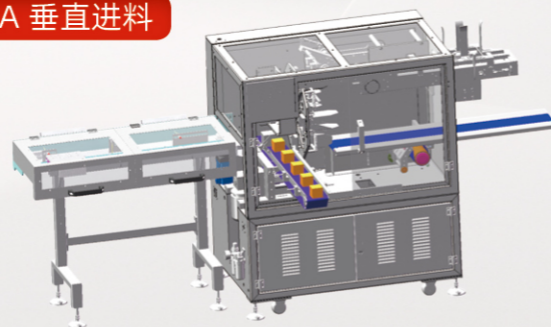
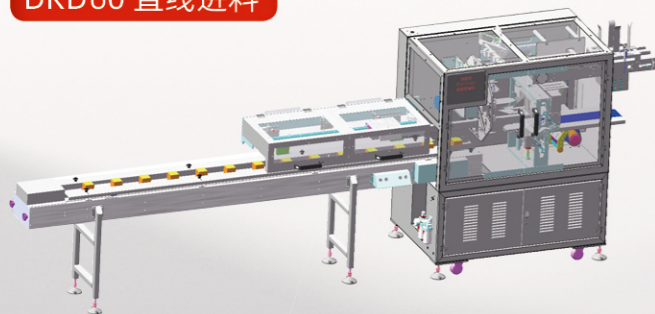

## 适用范围 APPLICATION SCOPE

自动套袋包装机主要针对方形吐司蛋糕类装预制袋的产品，前端可对接生产线实现自动连续供料、实现产品自动套袋包装形式。

The machine is mainly for square toast and cake with Prefabricated bag. The front end can be connected to the production line to realize automatic continuous feeding, automatic bagging and packaging.



## 性能特点 PERFORMANCE CHARACTERISTICS

1. 自动套袋包装机由送料尾架（或送料皮带）、推料机构、转盘、开袋机构以及输送皮带组成，通过多工位同时工作，实现开袋套袋同时进行，高效稳定。
2. 单条线包装速度：20-65 包 / 分钟，依产品尺寸和包装形式而定。  
标准机包装尺寸：长 70-170mmx 宽 70mmx 高 70mm（可根据产品定制模具）。  
包装形式：预制袋（平面袋、自立袋、拉链袋、M 袋等）。
3. 整线采用 220V 50Hz 电源，如图所示总功率约 5.2kW。  
气压：0.6KPa 耗气量：2.2 立方米 / 小时。

1. The automatic bagging and packing machine is composed of a feeding conveyor (or feeding belt), a pushing device, a turntable, a bag opening device, and a conveyor belt. Through bag opening and bagging can be working at the same time, which is efficient and stable.
2. Single line packaging speed: 20-65 bags/min, depending on product size and packaging form.  
Standard machine packaging size: 70-170mm(L) X 70mm(W) X 70mm(H) (the mold can be customized according to the product)  
Packaging form: prefabricated bag (flat bag, stand-up bag, zipper bag, M bag, etc.)
3. The whole line uses 220V 50Hz power supply, as shown in the figure, the total power is about 5.2Kw.  
air pressure: 0.6KPa air consumption: 2.2 cubic meters/hour



## 设备优势 EQUIPMENT ADVANTAGE

1. 整机采用直线推料或垂直皮带推料方式进料，具有占地小，节省厂房空间，提高空间利用率。
2. 整机设计为 4 工位结构，设计紧凑，运行由 PLC、大屏幕触摸屏集中控制，操作简单、方便。
3. 配套故障自动报警跟踪系统，实时显示运行状态。
4. 采用高灵敏度电眼检测物料及开袋，实现无袋不推料，防空包，有效降低次品率。
5. 主要传动系统采用伺服定位控制，定位精准、运行稳定、故障率低。

1. The whole machine adopts linear or vertical belt stacking method to feed materials, which has a small footprint, saves plant space and improves space utilization.
2. The whole machine is designed with a 4-station structure and compact design. Control by PLC and large-screen touch screen with simple and convenient operation.
3. Supporting fault automatic alarm tracking system, real-time display of operating status
4. Adopt high-sensitivity electric eye to detect materials and bags open, realize no bags without pushing materials, anti-air bags and effectively reduce the rate of defective products.
5. The main transmission system adopts servo positioning control, with accurate positioning, stable operation and low failure rate.



质量保障  
QUALITY ASSURANCE



精准操作  
PRECISE OPERATION



智能控制  
INTELLIGENT CONTROL



### 性能特点 PERFORMANCE CHARACTERISTICS

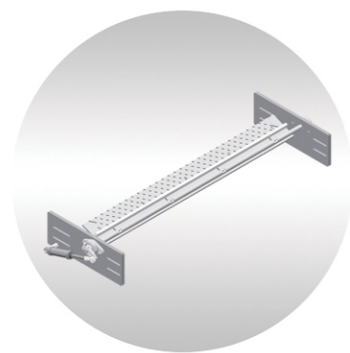

#### 一、输送平台翻面装置 TURN-OVER DEVICE OF CONVEYOR PLATFORM

- 1、结构简洁，方便快捷，性能稳定。
- 2、电眼检测，气缸控制，翻面精准。
- 3、适用于沙琪玛，米花糖等每排整齐来料的产品。

- 1.The structure is simple, convenient and fast, and the performance is stable.
2. Inspected and controlled by electric eye and cylinder, make the motion accurate.
3. Applied to the products incoming in order, such as Saqima, crunchy rice candy.



#### 二、移动式排齐装置 MOVABLE TYPE ALIGNMENT DEVICE

- 1、结构简洁，方便快捷，性能稳定。
- 2、对射电眼检测，气缸控制，定位准确。
- 3、可调挂钩式固定，整体可移动，拆装方便。

1. The structure is simple, convenient and fast, and the performance is stable.
2. The correlation electric eye detection, cylinder control, accurate positioning.
3. Fixed by adjustable hook, the whole device could be moved, dismount is convenient.

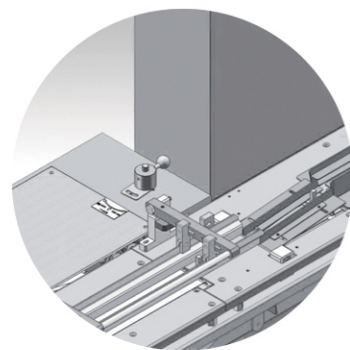

#### 三、叠层机构 LAMINATED MECHANISM

- 1、采用凸轮机构，性能稳定，噪音小。
- 2、结构简洁，方便清洁。
- 3、可通过更换凸轮和推料块，设置多种参数实现多种不同形态包装，如：2X1、2X2、2X3、3X1、3X2、3X3等，更换方便，简单。

1. Adopt cam structure, stable and low noise;
2. The structure is simple, easy to clean.
3. By changing cam and pushing blocks, setting different parameters to achieve various packaging forms, such as: 2x1, 2x2, 2x3, 3x1, 3x2, 3x3 and so on, easy to operate.

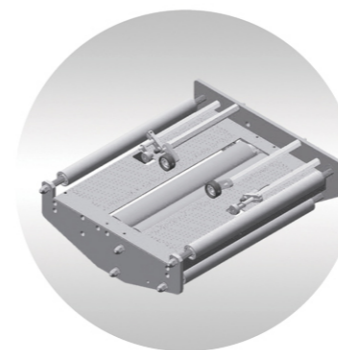

#### 四、自动接膜装置 AUTO SPLICER

- 1、结构简洁，方便快捷，性能稳定。
- 2、接膜快速，准确稳定，减少停机时间，便于自动化生产。

1. The structure is simple, convenient and fast, and the performance is stable.
2. Splicing film quickly, accurately, stably, which reduce downtime and easy for auto production.



#### 五、Y型尾架(投酒精片)装置

#### Y-SHAPE CONVEYOR (ALCOHOL PAD RELEASING) DEVICE

- 1、结构简单，可直接加装于标准理料线。
- 2、适用于产品投酒精片或干燥剂等。

1. Simple structure, could be installed in the standard packing lines.
2. It is used for releasing alcohol pad, desiccant and so on.

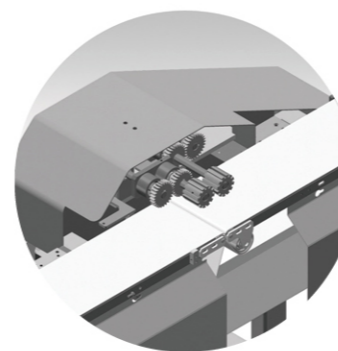

#### 六、分离机构 SEPARATING DEVICE

- 1、结构简洁，性能稳定，与输送同步。
- 2、适用于沙琪玛，米花糖等切割类产品辅助分离。

1. Simple structure, stable performance, could synchronize to the conveyor.
2. As an auxiliary separating device, applied to cutting type products, such as Saqima, crunchy rice candy and so on.

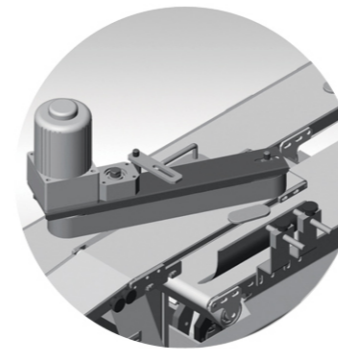

#### 七、单通道翻面装置 SINGLE TUNNEL TUM-OVER DEVICE

- 1、结构简洁，性能稳定。
- 2、翻面精准，方便快捷，如饼干类翻面速度可达每分钟300个。
- 3、适用于单列需要翻面包装的产品，如饼干，华夫饼等。

1. Simple structure, stable performance.
2. The motion of turn-over is accurate, convenient and fast; the turn-over speed of biscuit can reach to 300 pieces per minute.
3. Applied to the products which need to be turn over in single row, such as biscuit, waffle and so on.

# HONOR CERTIFICATE

## 荣誉证书



专利申请累计近百项

A total of nearly 100 patent applications



CCTV 2  
财经

# 经济半小时

瑞普华 RUIPUHUA | realpower®  
中央电视台财经频道经济半小时专访品牌

